

# SERVICE MANUAL

## PARTS LIST

**MODEL AA-1010**



**AKAI STEREO RECEIVER**

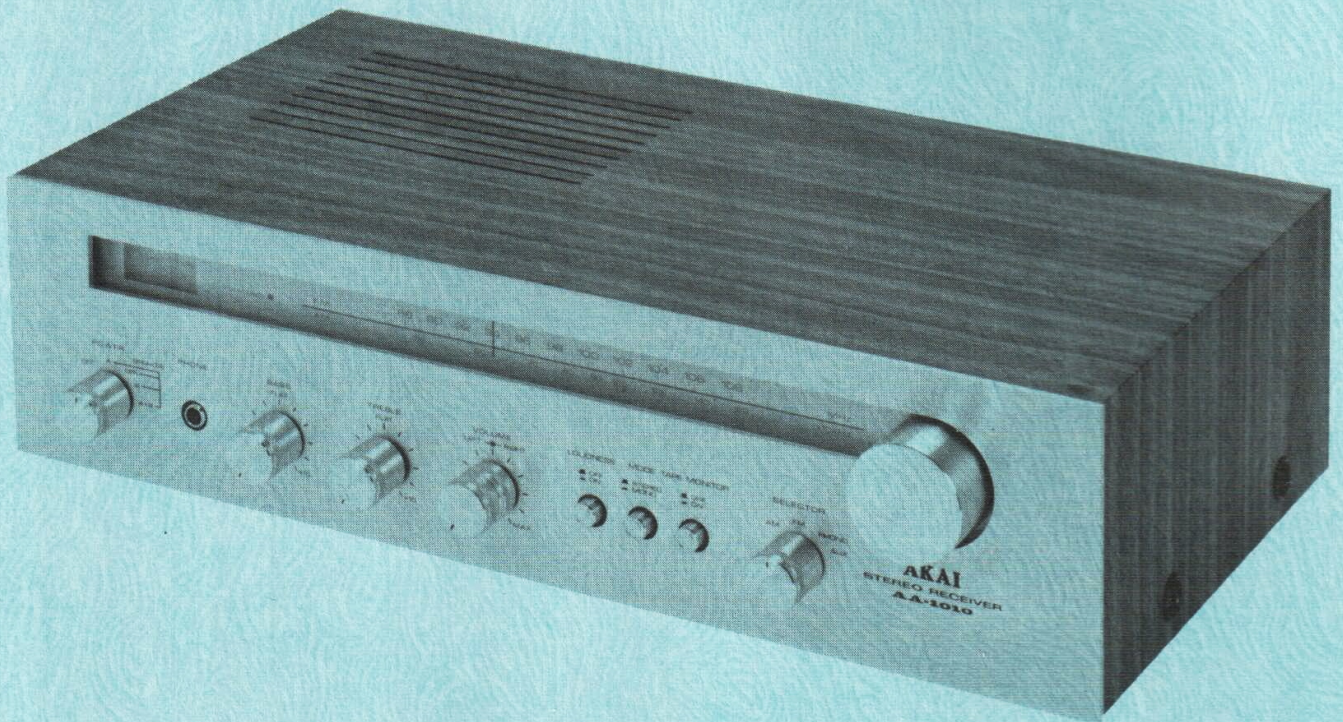

## AKAI STEREO RECEIVER

### MODEL AA-1010

SECTION 1 SERVICE MANUAL .....	3
SECTION 2 PARTS LIST .....	19

## SECTION 1

# SERVICE MANUAL

### TABLE OF CONTENTS

I.	TECHNICAL DATA .....	4
II.	DISMANTLING OF UNIT .....	5
III.	PRINCIPAL PARTS LOCATION .....	6
IV.	OPERATING PRINCIPLES OF QUADRATURE DETECTION SYSTEM .....	7
V.	OPERATING PRINCIPLES OF PLL CIRCUIT EMPLOYED IN FM STEREO DEMODULATION CIRCUIT .....	8
	1. PLL CIRCUIT OPERATION .....	8
	2. STEREO DEMODULATION CIRCUIT .....	8
VI.	FM TUNER SECTION ADJUSTMENT .....	10
VII.	AM TUNER SECTION ADJUSTMENT .....	12
VIII.	MAIN AMPLIFIER ADJUSTMENT .....	13
IX.	TUNING CORD THREADING .....	14
X.	CLASSIFICATION OF VARIOUS P.C BOARDS .....	15
	1. RELATION OF P.C BOARD TITLE AND IDENTIFICATION NUMBER .....	15
	2. COMPOSITION OF VARIOUS P.C BOARDS .....	16

For basic adjustments, measuring methods, and operating principles, refer to GENERAL OPERATING PRINCIPLES AND ADJUSTMENTS.

# I. TECHNICAL DATA

## 1. AMPLIFIER SECTION

CONTINUOUS POWER OUTPUT		14 watts per channel, min. RMS, at 8 ohms from 40 Hz to 20,000 Hz with no more than 0.8% total harmonic distortion.
POWER BAND WIDTH (IHF)		15 Hz to 40,000 Hz/8 ohms (Distortion within 0.8%)
INPUT SENSITIVITY	PHONO	3 mV/47 k ohms
	TAPE	150 mV/100 k ohms
	AUX	150 mV/100 k ohms
SIGNAL TO NOISE RATIO (IHF)	PHONO	Better than 80 dB
	AUX	Better than 90 dB
CHANNEL SEPARATION (IHF)	PHONO	Better than 50 dB at 1,000 Hz
EQUALIZER		RIAA $\pm 1$ dB (Phono)
TONE CONTROL	BASS	$\pm 10$ dB at 100 Hz
	TREBLE	$\pm 10$ dB at 10 kHz
LOUDNESS CONTROL		$\pm 10$ dB at 100 Hz, +5 dB at 10 kHz (Volume control set at -30 dB position)

## 2. FM TUNER SECTION

FREQUENCY RANGE	88 MHz to 108 MHz
SENSITIVITY (IHF)	2.0 $\mu$ V
CAPTURE RATIO (IHF)	1.5 dB
SELECTIVITY (IHF)	Better than 60 dB at 98 MHz
SIGNAL TO NOISE RATIO	Better than 65 dB
IMAGE REJECTION	Better than 55 dB at 98 MHz
IF REJECTION	Better than 70 dB at 98 MHz
SPURIOUS REJECTION	Better than 70 dB at 98 MHz
HARMONIC DISTORTION	Monaural: Less than 0.3%
	Stereo: Less than 0.6%
FM STEREO SEPARATION	Better than 40 dB at 1,000 Hz
ANTENNA INPUT IMPEDANCE	300 ohms balanced, 75 ohms unbalanced

## 3. AM TUNER SECTION

FREQUENCY RANGE	520 kHz to 1,605 kHz
SENSITIVITY (IHF)	200 $\mu$ V/m (Bar Antenna)
	8 $\mu$ V/m (EXT Antenna)
IMAGE REJECTION	Better than 55 dB at 1,000 kHz
IF REJECTION	Better than 45 dB at 1,000 kHz
SELECTIVITY (IHF)	Better than 30 dB at 1,000 kHz
AM DISTORTION	Less than 1.0%
SIGNAL TO NOISE RATIO	Better than 45 dB

## 4. OTHER

TRANSISTOR	2SA733(P)(Q)(R) ... 1	2SC1222(E)(F) ... 4
	2SB605(L)(M) ... 4	2SD313(E)(F) ... 5
	2SC930(E)(F) ... 1	2SD571(L)(M) ... 2
	2SC945L(P)(Q)(R)(S) ... 2	
IC	LA1230Z ... 1	LA3350 ... 1
	LA3122 ... 1	$\mu$ PC30C ... 1
DIODE	1S2473 ... 2	WZ130 ... 1
	10D2 ... 2	SEL105RC ... 1
	VD1222 ... 2	
POWER REQUIREMENT	CSA, UL and LA Models ... 120V, 60 Hz CDD Models ... 220V, 50 Hz Other Models ... 110V/220V/240V (Switchable)	
DIMENSIONS	440(W)x125(H)x265(D)mm 17.3(W)x4.9(H)x10.4(D)inches	
WEIGHT	6.4 kg (14.0 lbs)	

NOTE: For improvement purposes, specifications and design are subject to change without notice.

## II. DISMANTLING OF UNIT

In case of trouble, etc. necessitating disassembly, please disassemble in the order shown in photographs. Reassemble in reverse order.

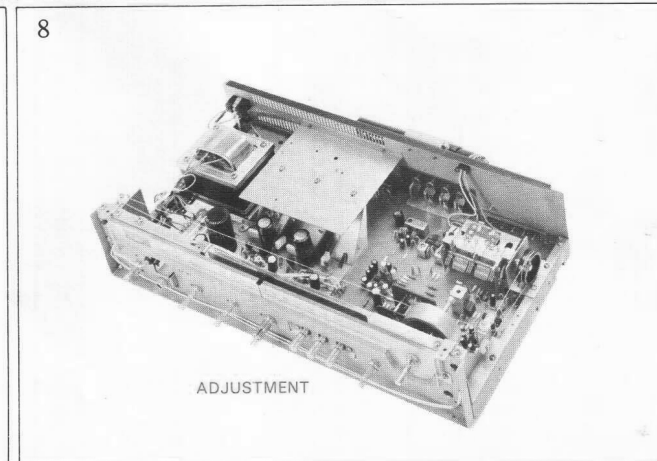
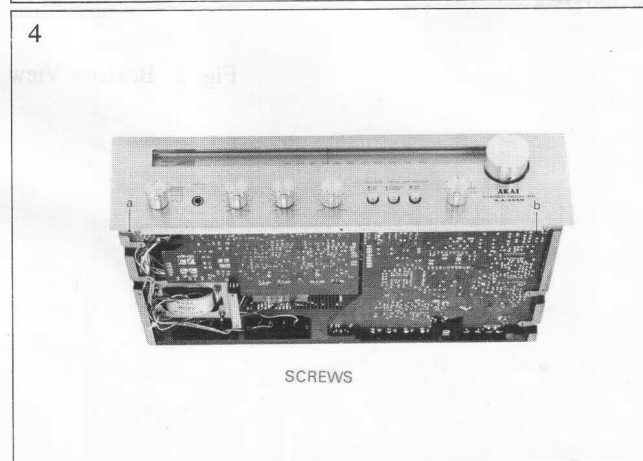
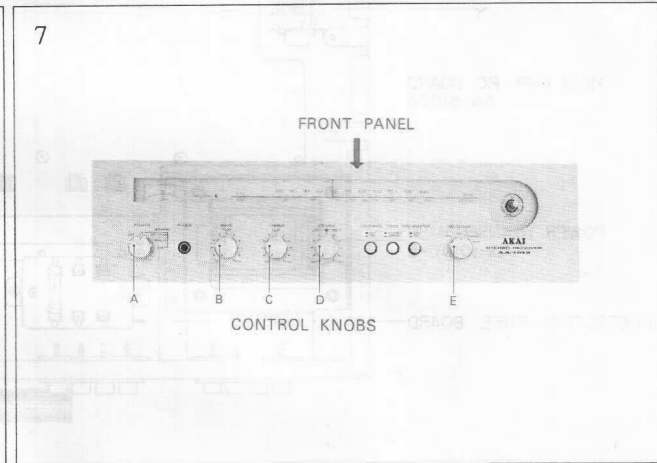
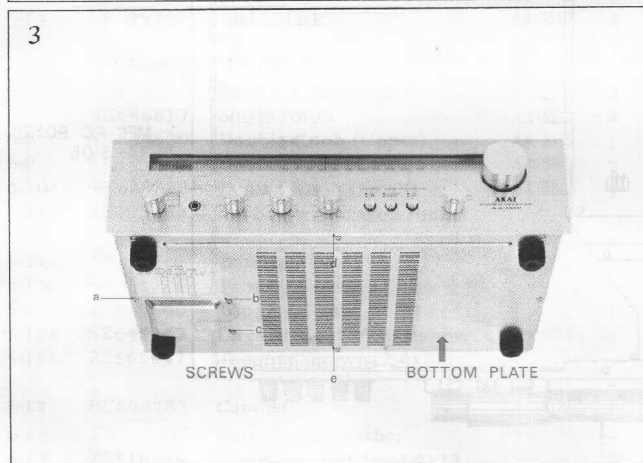
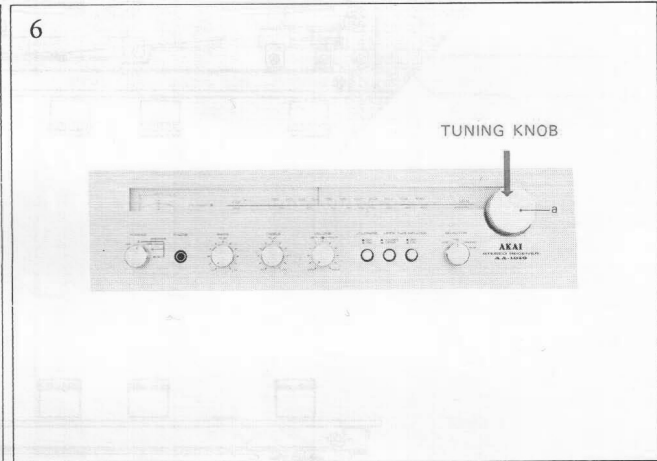
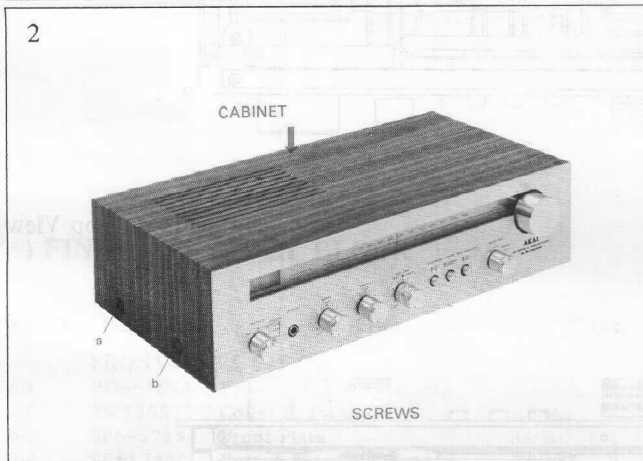
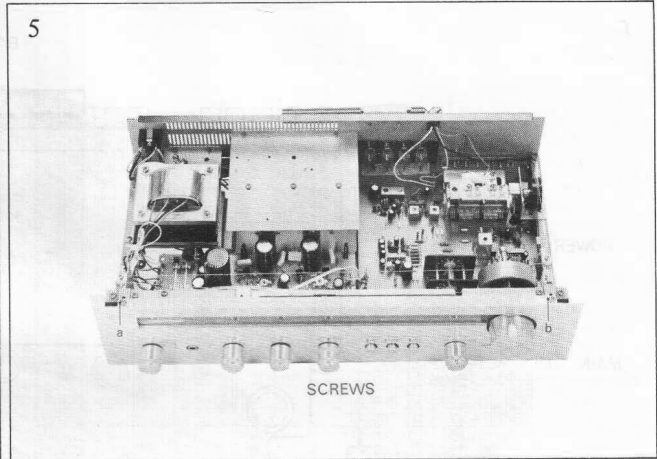
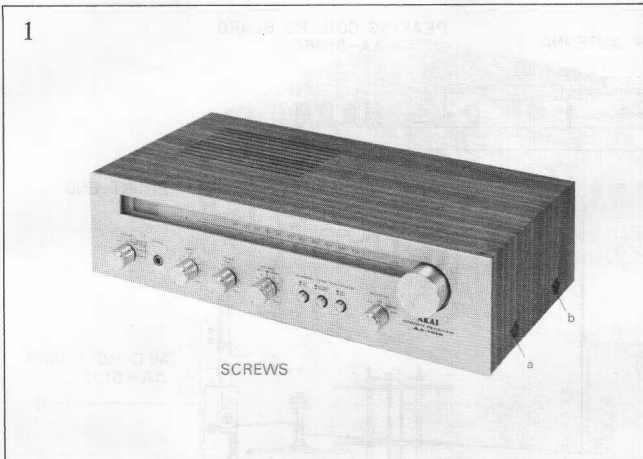

### III. PRINCIPAL PARTS LOCATION

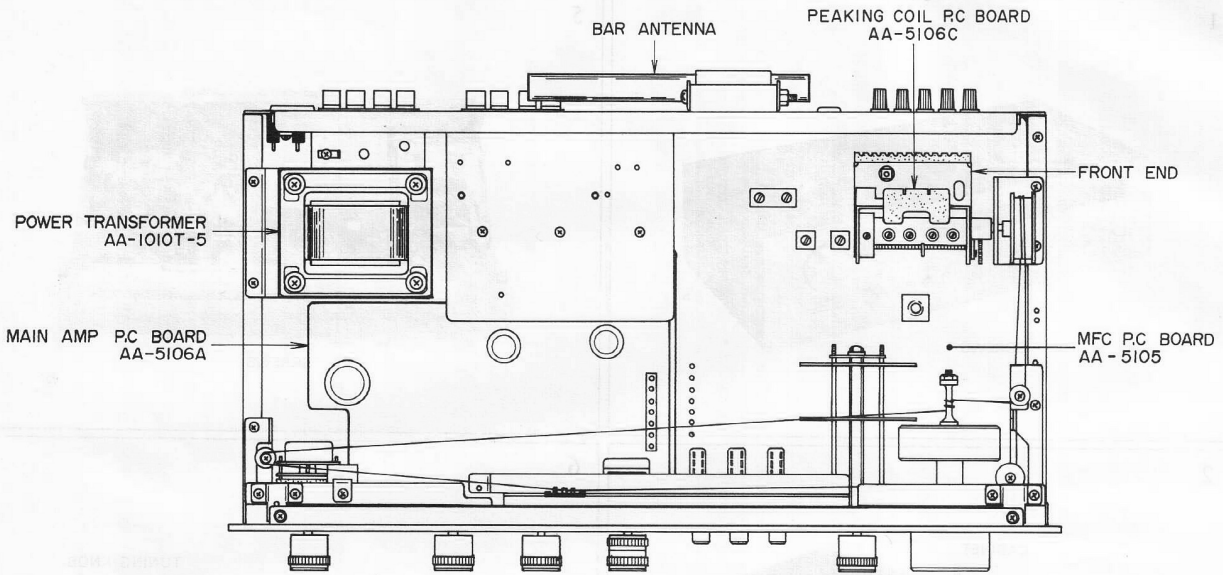

Fig 1 Top View

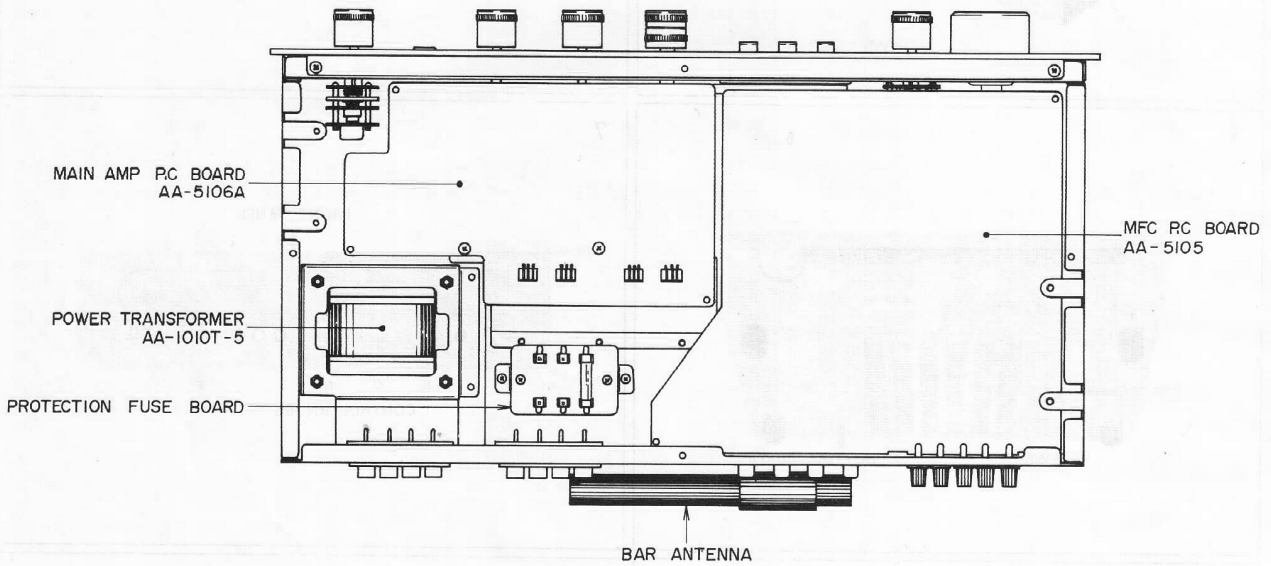

Fig. 2 Bottom View

# IV. OPERATING PRINCIPLES OF QUADRATURE DETECTION SYSTEM

The Quadrature Detection Circuit is comprised of a Phase Circuit, a Multiplier Circuit and a Low Pass Filter (L.P.F.) as shown in Fig. 3.

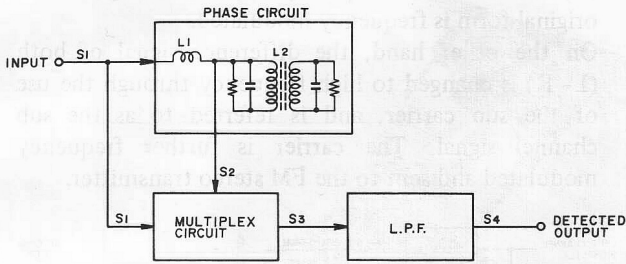

Fig. 3 Quadrature Detection Block Diagram

There are two types of Phase Circuits, the Single tuning type shown in Fig. 4 and the Double tuning type shown in Fig. 5. However, because with the double tuning type there is less frequency deviation in relation to carrier frequency, linearity is improved as shown in Fig. 6, and phase distortion is reduced, this type phase circuit is employed in the AA-1010.

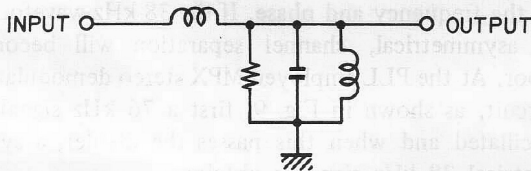

Fig. 4 Single Tuning Type

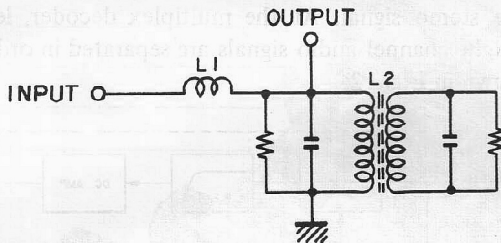

Fig. 5 Double Tuning Type

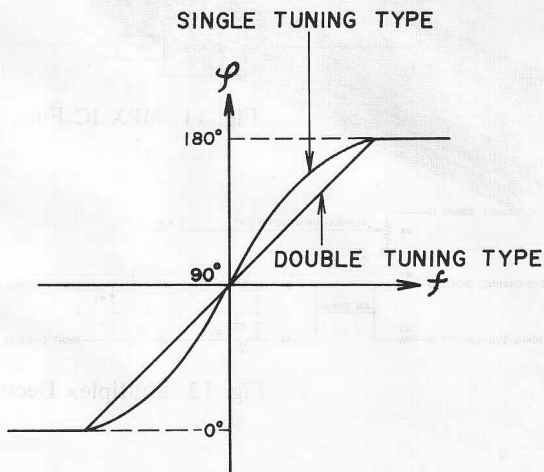

Fig. 6 Tuning Curve

Input signal S1 is divided into the part which enters the direct multiplier circuit and the part which passes the phase circuit and enters the multiplier circuit. The signal supplied to the phase circuit as always 90° phase delayed at L1. Also because at Non-modulation time, L2 is tuned to 10.7 MHz, if modulation is applied and S1 is changed from 10.7 MHz, phase deviation at L2 will take place proportionately in relation to this changed part and this becomes S2 signal which is delayed in relation to S1.

At Non-modulation, because as shown in Fig. 7, input signal S1 and 90° phase delayed (by means of L1) signal S2 are switched by means of the multiplier circuit, the output signal becomes S3.

Because this S3 passes the low pass filter and becomes S4 fixed direct current, the detector output zero.

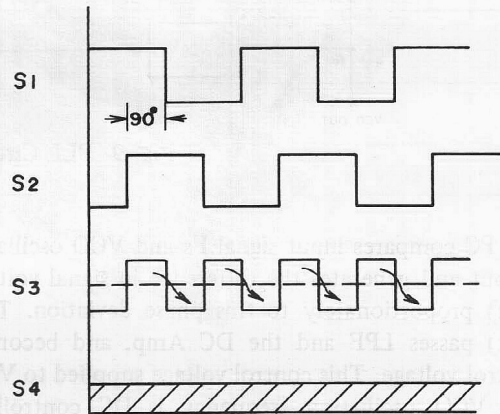

Fig. 7 Output at Non-modulation

Then, when modulation is applied, because the switched output is varied according to the degree of modulation, and the output which passed the low pass filter becomes the pulsating current part as shown in Fig. 8, detector output is obtained.

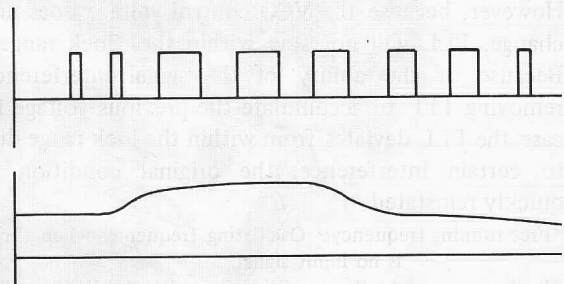

Fig. 8 Output at Modulation Time

# V. OPERATING PRINCIPLES OF PLL CIRCUIT EMPLOYED IN FM STEREO DEMODULATION CIRCUIT

To separate FM stereo broadcast signal received to date into left and right signals, a 19 kHz pilot signal was successively multiplied to form a 38 kHz signal and stereo separation was effected from this. However, with this multiplier system, change in coils due to wear occurred and adjustment points were numerous, etc. Therefore, this model employs a newly developed PLL circuit which produces an exceedingly accurate 38 kHz switching signal.

## 1. PLL CIRCUIT OPERATION

PLL circuit is a kind of feedback circuit and is comprised of a Phase Comparator (PC), a Low Pass Filter (LPF), a Direct Current Amplifier (DC Amp.), and a Voltage Control Oscillator (VCO) as shown in Fig. 9.

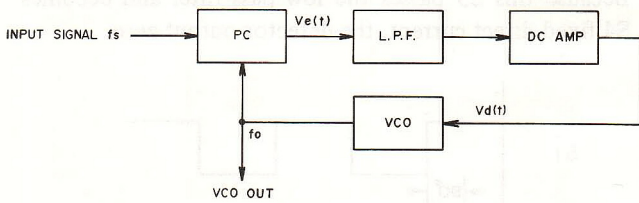

Fig. 9 PLL Circuit

The PC compares input signal  $F_s$  and VCO oscillator output and generates the difference in signal voltage  $V_e(t)$  proportionately to this phase deviation. This  $V_e(t)$  passes LPF and the DC Amp. and becomes control voltage. This control voltage supplied to VCO and VCO oscillation frequency is DC controlled. When there is no input signal  $F_s$ , because there is also no  $V_e(t)$ , control voltage  $V_d(t)$  becomes zero, and VCO maintains a \*free-running oscillation frequency. When a signal enters, VCO oscillation frequency  $F_o$  is controlled to narrow the difference between  $F_s$  by means of feedback as described above, and the PLL circuit assumes a synchronous condition. This is referred to as input signal lock. (In case the difference between  $F_o$  and  $F_s$  is too large, the differential signal frequency becomes high and is reduced at the LPF. However, because the VCO control voltage does not change, PLL will not stay within the \*lock range). Because of the ability of the signal interference removing LPF to accumulate the previous voltage in case the PLL deviates from within the lock range due to certain interference, the original condition is quickly reinstated.

\*Free running frequency: Oscillating frequency when there is no input signal.

\*Lock range: At the condition in which the VCO oscillation frequency is locked to the input signal, the lock range is the oscillating frequency in which when the input signal changes, the PLL maintains its input signal lock condition.

Accordingly, in case  $F_s$  is changed inside the PLL lock range, VCO oscillation frequency always follows this, and a no frequency deviation and no phase difference signal is obtained.

In other words, VCO oscillation frequency can be locked to  $F_s$ .

## 2. STEREO DEMODULATION CIRCUIT

As shown in Fig. 10, for FM broadcasts, the sum signal (L+R) consists of left signal (L) and right signal (R) and the audio frequency band of this signal in its original form is frequency modulated.

On the other hand, the difference signal of both (L-R) is changed to high frequency through the use of the sub carrier, and is referred to as the sub channel signal. The carrier is further frequency modulated and sent to the FM stereo transmitter.

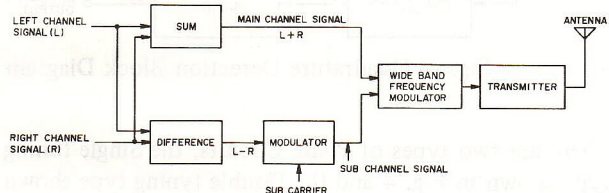

Fig. 10 FM Broadcasting System Diagram

Accordingly, for composite stereo signal demodulation, the sub carrier used for demodulation at the transmitter must be the same uniform 38 kHz signal as the frequency and phase. If the 38 kHz waveform is asymmetrical, channel separation will become poor. At the PLL employed MPX stereo demodulator circuit, as shown in Fig. 9, first a 76 kHz signal is oscillated and when this passes the divider, a symmetrical 38 kHz signal is obtained.

This 38 kHz sub carrier is supplied to the multiplex decoder together with the sub channel of the composite stereo signal. At the multiplex decoder, left and right channel audio signals are separated in order as shown in Fig. 12.

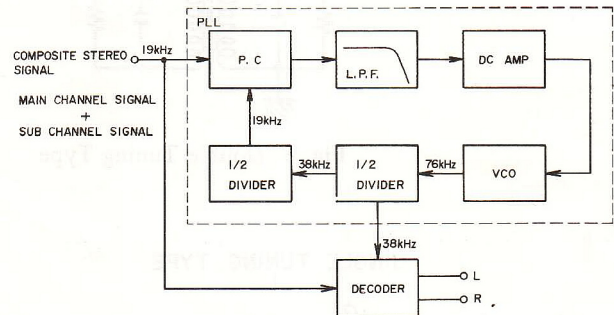

Fig. 11 MPX IC Function

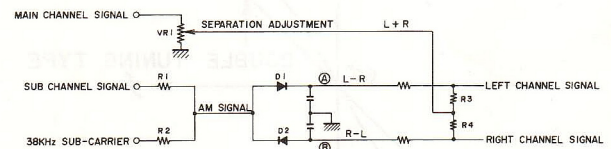

Fig. 12 Multiplex Decoder



The 38 kHz sub carrier composited with the sub channel signal of which the carrier part was removed when sub channel signal and sub carrier passed R1 R2 produces the regular AM wave. Then, because this envelops is detected by mutually reverse polarity connected diodes D1 and D2, L-R signal is emitted at point (A) and R-L signal at point (B).

Also, because main channel signal (L+R) is supplied to R3, R4 center point, (A)(B) point voltage is added and subtracted and becomes

$$(L+R) + (L-R) = 2L \text{ (left channel)}$$

$$(L+R) + (R-L) = 2R \text{ (right channel)}$$

The level of the main channel signal (L+R) can be adjusted by means of variable resistor VR (VR1) for optimum separation.

Thus, the function of actually employed PLL IC LA-3350 is a shown in Fig. 13.

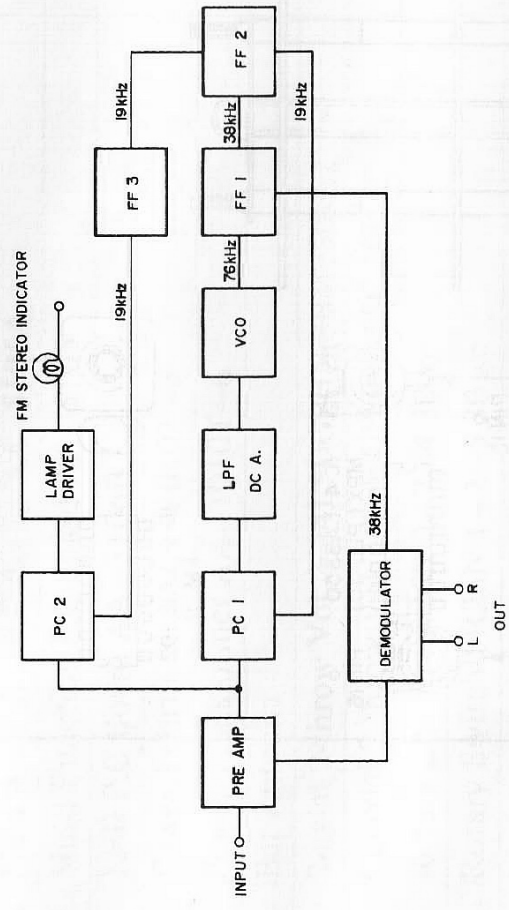

Fig. 13 LA-3350 Function System Diagram

# VI. FM TUNER SECTION ADJUSTMENT

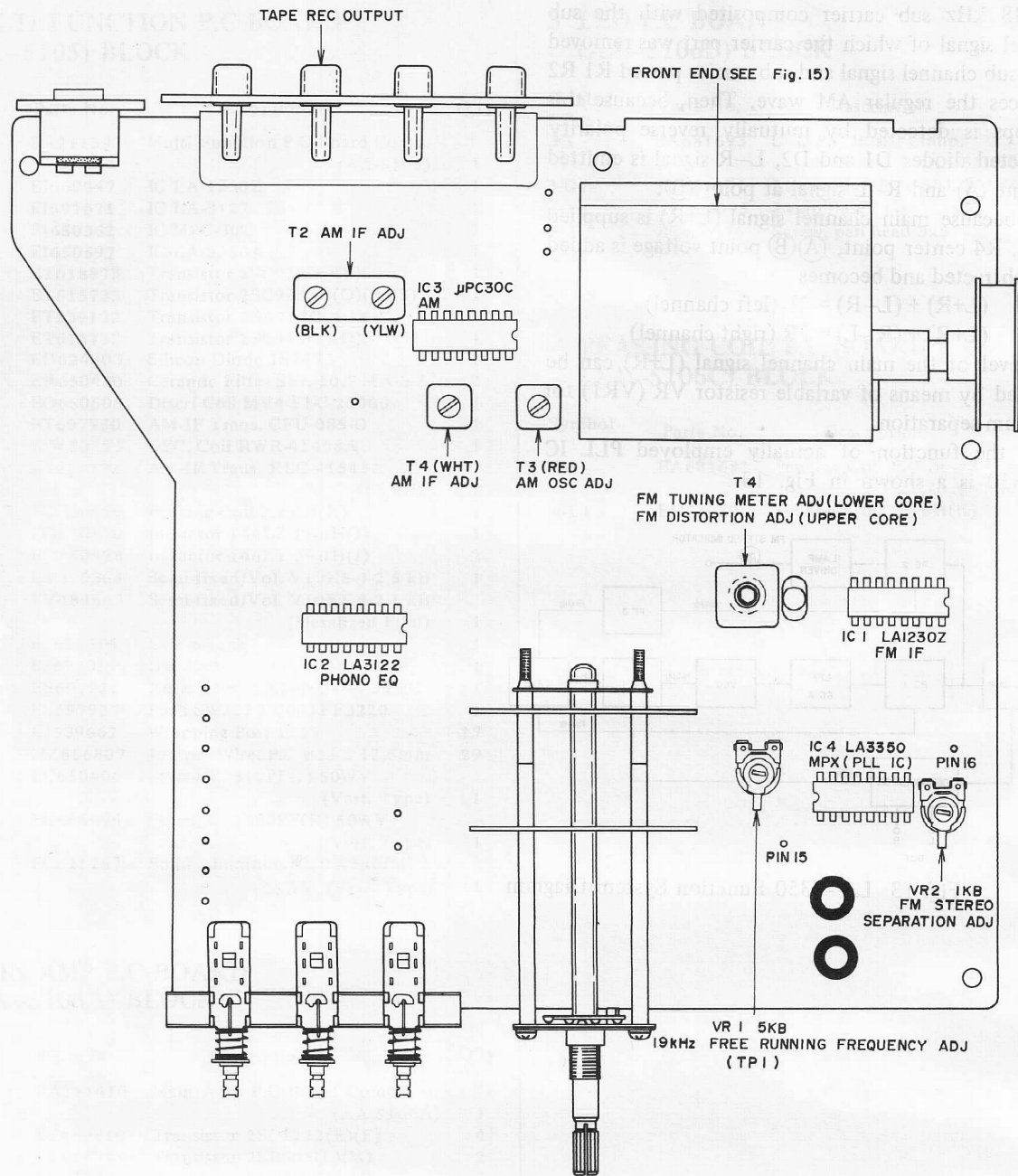

Fig. 14 Multi Function P.C Board AA-5105

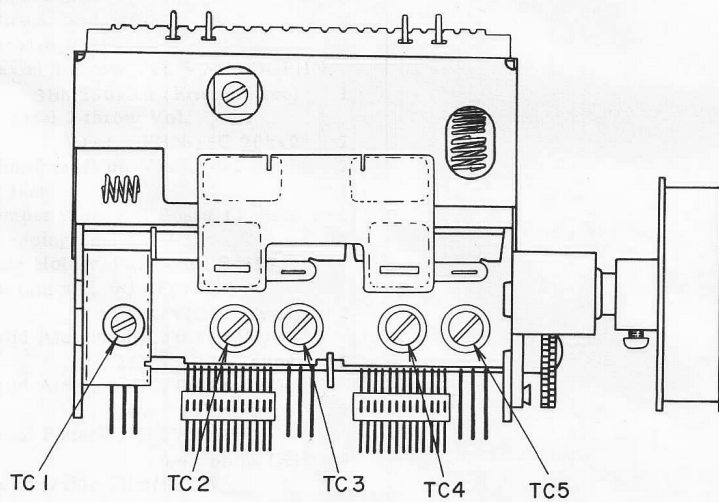
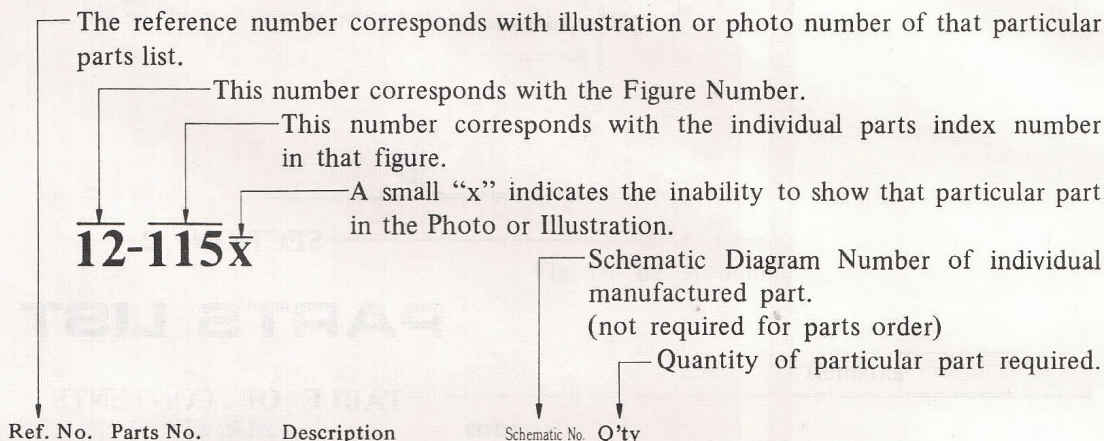

Fig. 15 Front End

## HOW TO USE THIS PARTS LIST

1. This parts list is compiled by various individual blocks based on assembly process.
2. When ordering parts, please describe parts number, serial number, and model number in detail.
3. How to read list.



FLYWHEEL BLOCK #13				
Ref. No.	Parts No.	Description	Schematic No.	Q'ty
12-115x	800425	Flywheel Block Assy. Comp.	RDG #13	1
12-116	244506	Flywheel Only	RD-233	1
12-117x	244754	Felt, Flywheel	RD-275	1
12-118	251324	Main Metal Case	RD-236	1
12-119	253080	Main Metal	RD-237	1

4. The symbol numbers shown on the P.C. Board list can be matched with the Composite Views of components of the Schematic Diagram or Service Manual.
5. The indications of Resistors and Capacitors in the photos of P.C. Board are being eliminated.
6. The shape of the parts and parts name, etc. can be confirmed by comparing them with the parts shown on the Electrical Parts Table of P.C. Board.
7. Both the kind of part and installation position can be determined by the Parts Number. To determine where a parts number is listed, utilize Parts Index at end of Parts List.  
It is necessary first of all to find the Parts Number. This can be accomplished by using the Reference Number listed at right of parts number in the Parts Index. (meaning of ref. no. outlined in Item 3 above).
8. Utilize separate "Price List for Parts" to determine unit price. The most simple method of finding parts Price is to utilize the reference number.

## VII. AM TUNER SECTION ADJUSTMENT

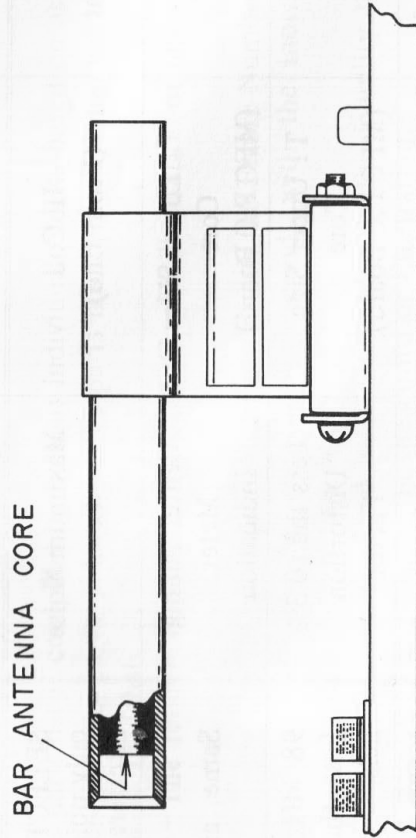

Fig. 16 Bar Antenna

Step	Adjustment Item	Adjustment Point	Result	Remarks
1	Low Range Frequency Coverage Adjustment	T3 (RED) (MFC P.C Board)	error within 2%	520 kHz optional input
2	Sensitivity Adjustment	Bar Antenna core T2 (YLW, BLK) T4 (WHT) (MFC P.C Board)	maximum sensitivity	520 kHz optional input
3	High Range Frequency Coverage Adjustment	TC2 (Front End)	error: within 2%	1,400 kHz optional input
4	Sensitivity Adjustment	TC4 (Front End)	maximum sensitivity	1,400 kHz optional input

NOTE: Repeat procedures in steps 1 through 4.

## VIII. MAIN AMPLIFIER ADJUSTMENT

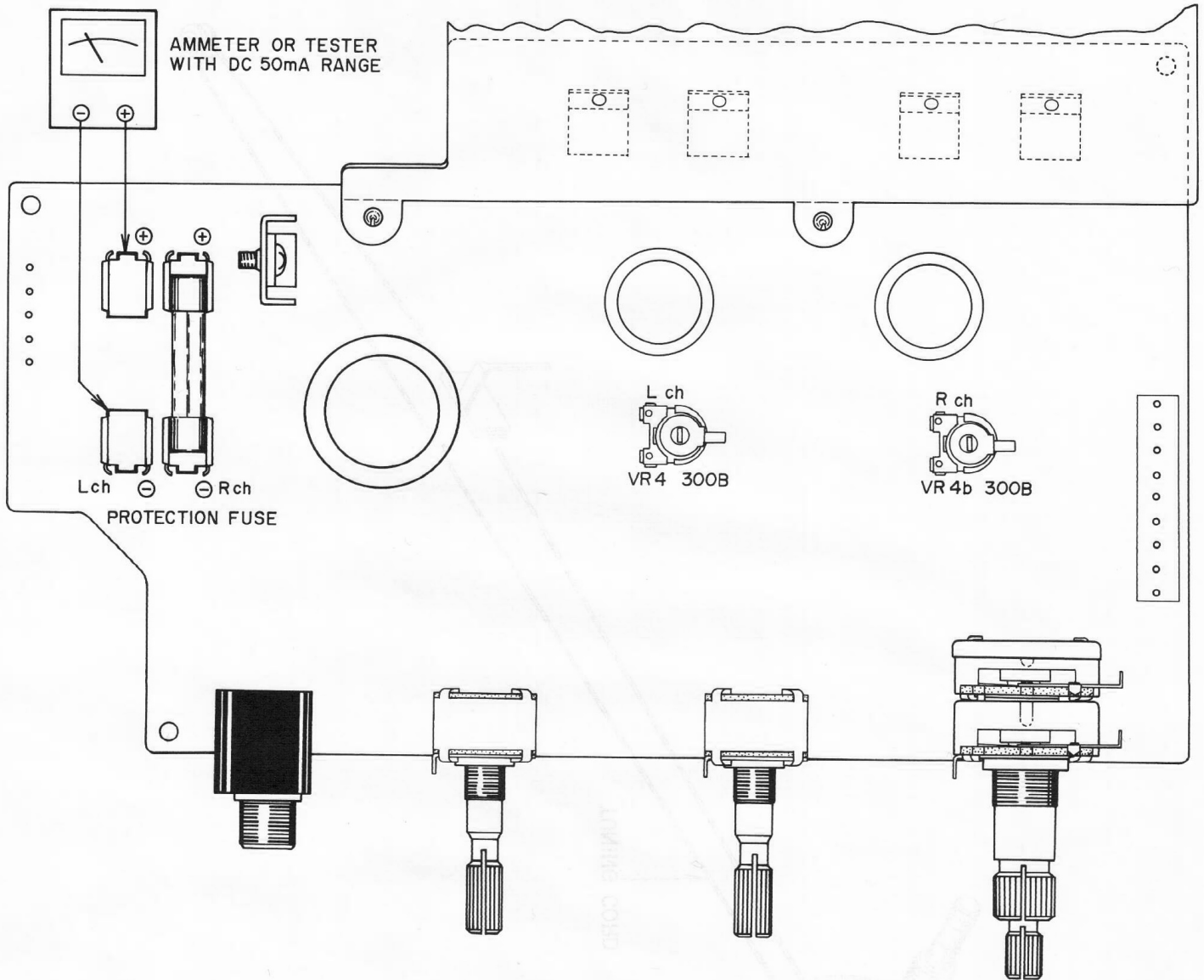
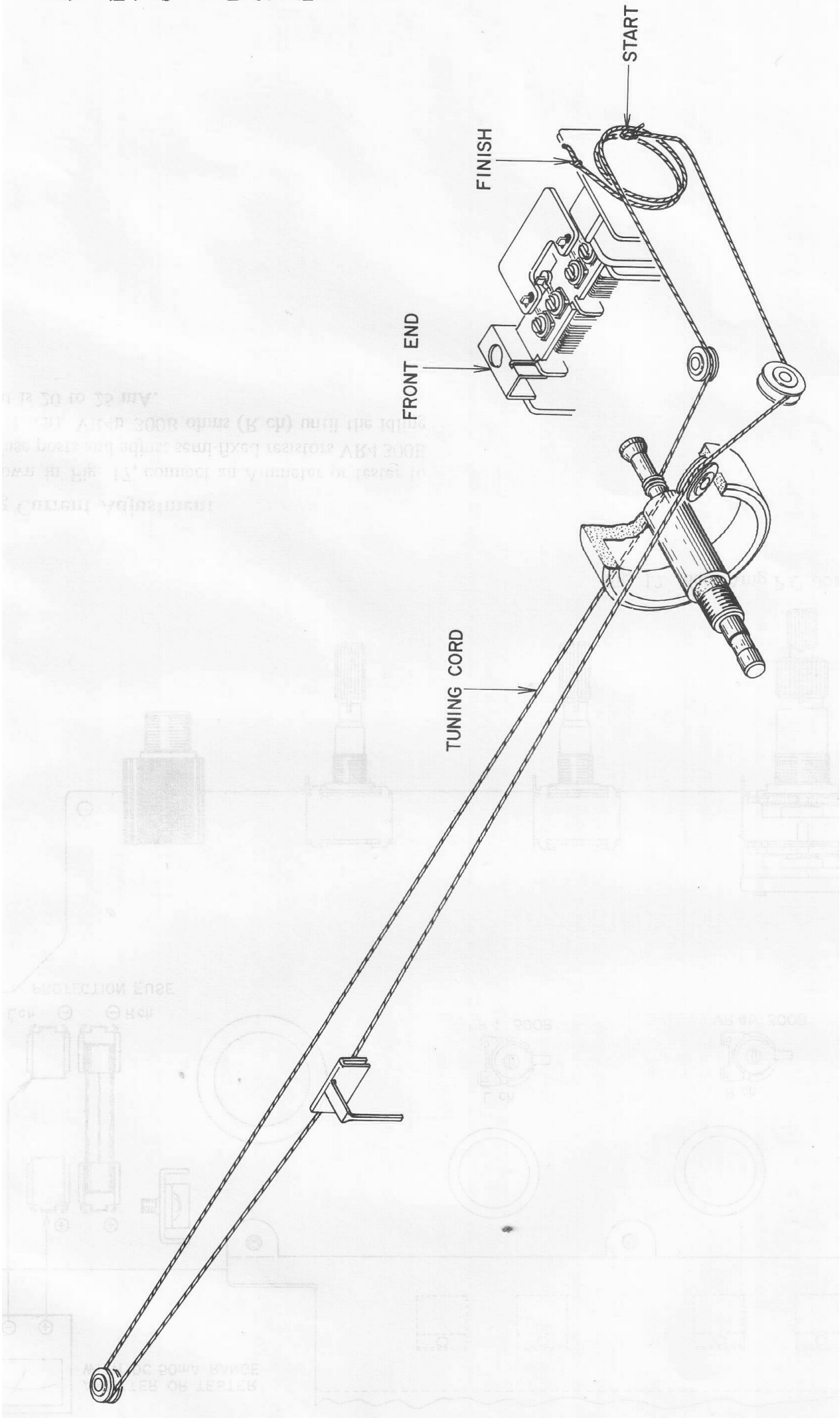

Fig. 17 Main Amp P.C Board AA-5106

### Idling Current Adjustment

As shown in Fig. 17, connect an Ammeter or tester to both fuse posts and adjust semi-fixed resistors VR4 300B ohms (L ch), VR4b 300B ohms (R ch) until the idling current is 20 to 25 mA.

Fig. 18 Tuning Cord Threading



# X. CLASSIFICATION OF VARIOUS P.C BOARDS

## 1. RELATION OF P.C BOARD TITLE AND IDENTIFICATION NUMBER

P.C Board	Number of P.C Board
Multi Function P.C Board	AA-5105
Main Amp P.C Board	AA-5106A
LED P.C Board	AA-5106B
Peaking Coil P.C Board	AA-5106C

Chart-3

## 2. COMPOSITION OF VARIOUS P.C BOARDS

### 1) MULTI FUNCTION P.C BOARD AA-5105

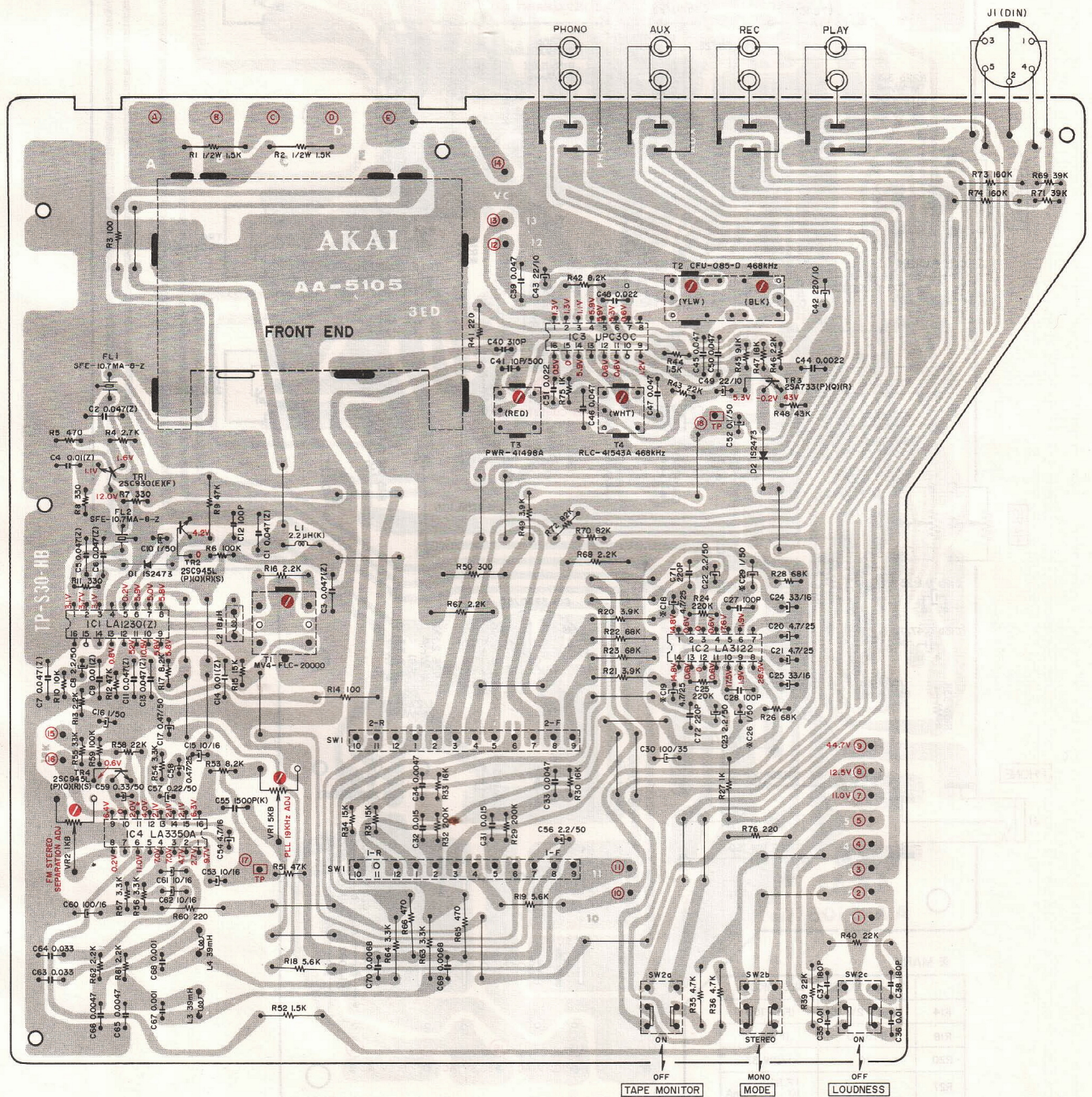

2) MAIN AMP P.C BOARD AA-5106A

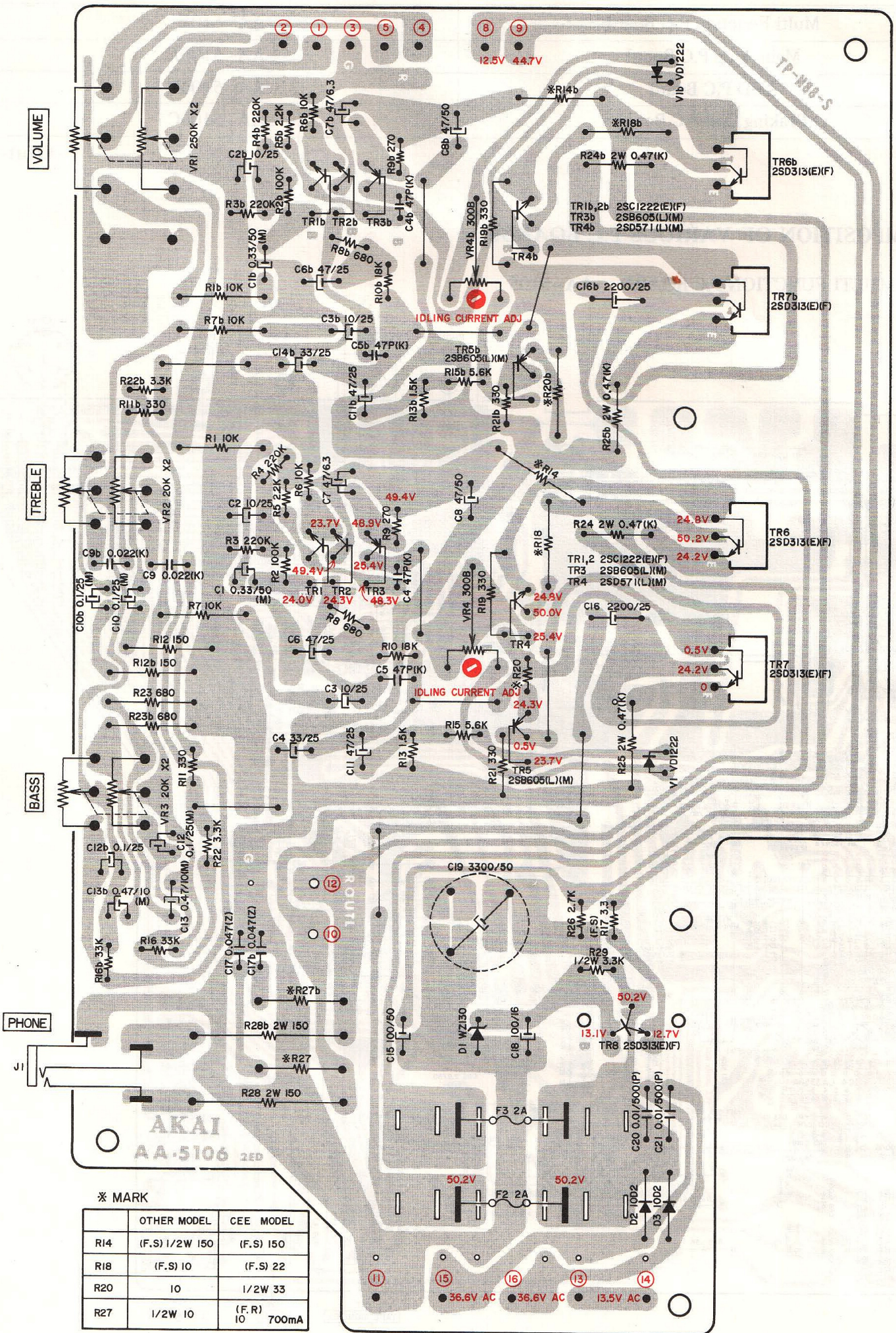



3) LED P.C BOARD AA-5106B

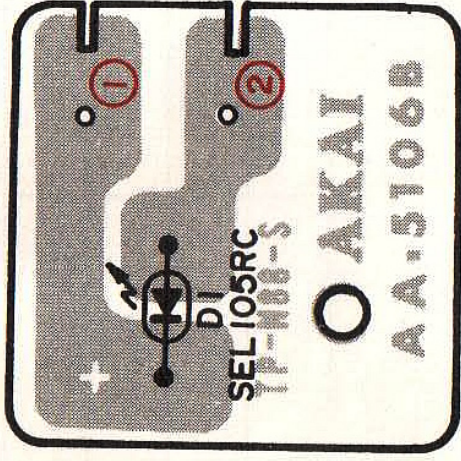

4) PEAKING COIL P.C BOARD AA-5106C

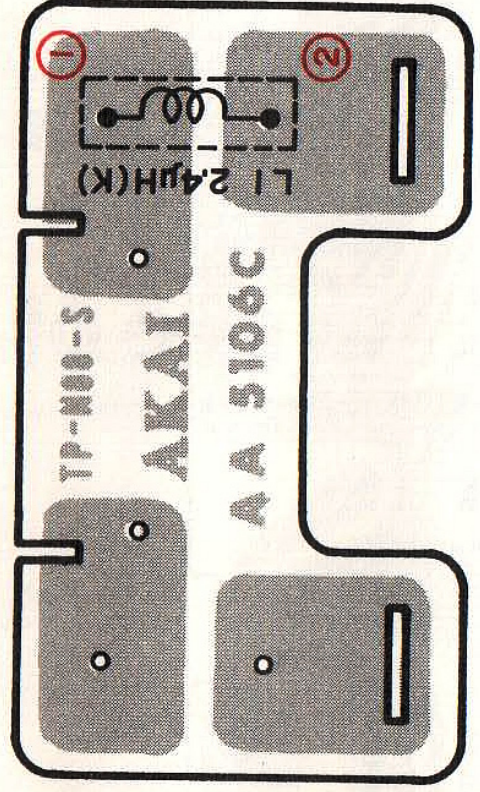

## BASIC PARTS LIST

Parts Nomenclature	Parts No.	Note
Cabinet AA-5123	EC699783	
Front Panel Block Comp.	BD681636	
Scale Plate AA-5125	TA699794	
Push Button Knob J	SK634410	Same as Model AA-1010DB
Single Knob AA-5250	SK646817	Same as Model AA-1010DB
Double Knob (Upper) AA-5355	SK644670	Same as Model AA-1010DB
Double Knob (Lower) AA-5353	SK645208	Same as Model AA-1010DB
Tuning Knob (Small) AA-5252	SK646828	Same as Model AA-1010DB
Tuning Meter KL-218D-94	EM655727	M-1
Front End FB512U13	TA655301	Same as Model AA-1010DB
Peaking Coil P.C Board AA-5106C	BA681682	
Main Amplifier P.C Board AA-5106A	BA681671	
Multi Function P.C Board AA-5105	BA681660	
LED P.C Board AA-5106B	BA681693	
Power Transformer AA-1010T-5	BT699805	Model AA-1010
Power Transformer AA-1010T-6	BT698297	Model AA-1010 (CSA)
Bar Antenna	EE699816	
2-axial 2-throw Vol. V24L5DGPIN 3BM250kx2	EV698264	
Co-axial 2-throw Vol. V16L GPHN-15C 20kx2	EV698275	
Rotary Switch SR26N 2-7-4 30 kc	ES697926	
Rotary Switch SR26N 1-2-5 30 kc	ES655706	Same as Model AA-1010DB
Push Switch 2FT-0001 FF3220	ES697931	
Lamp (Cord Type) 14 Volt 100 mA (650M/Mx2)	EL650193	IND-1
Lamp (Cord Type) 14 Volt 100 mA (200M/Mx2)	EL650158	IND-2, IND-3

## 1 MULTI FUNCTION P.C BOARD (AA-5105) BLOCK

Symbol No.	Parts No.	Description	Q'ty
1-1	BA211397	Multi Function P.C Board Comp. (AA-5105)	1
1-IC1	EI669047	IC LA-1230Z	1
1-IC2	EI697871	IC LA-3122	1
1-IC3	EI650362	IC MPC-30C	1
1-IC4	EI650597	IC LA-3350A	1
1-TR1	ET618873	Transistor 2SC930(E)(F)	1
1-TR2	ET515733	Transistor 2SC945(P)(Q)(R)(S)	1
1-TR3	ET539122	Transistor 2SA733(P)(Q)(R)	1
1-TR4	ET515733	Transistor 2SC945(P)(Q)(R)(S)	1
1-D1,2	ED624903	Silicon Diode 1S2473	2
1-FL1,2	ER650430	Ceramic Filter SFE-10.7 MA-8-Z	2
1-T1	EO650608	Discri Coil MV4-FLC-20000	1
1-T2	BT697950	AM-IF Trans. CFU-085-D	1
1-T3	EO650395	OSC. Coil RWR-41498A	1
1-T4	BT650373	AM-IF Trans. RLC-41543A 468 kHz	1
1-L1	EO539820	Peaking Coil 2.2 $\mu$ H(K)	1
1-L2	EO650610	Inductor 144LZ 18 $\mu$ H(J)	1
1-L3,4	EO650428	Inductor 146LY 39 $\mu$ H(J)	2
1-VR1	EV499364	Semi-fixed/Vol. V10K8-4-2 5 kB	1
1-VR2	EV484863	Semi-fixed/Vol. V10K8-4-2 1 kB (Metalized Film)	1
1-J1	EJ655334	8P Pin Jack	1
1-J2	EJ698051	Din Jack	1
1-SW1	ES697926	Rotary SW. SR26N 2-7-4 30 kC	1
1-SW2	ES697937	Push SW. 3FT-0001FF3220	1
1-2	EJ539662	Wrapping Post 1x17	17
1-3	MZ656807	Jumper Wire, P.C Board 12.5mm	29
1-C40	EC650406	Styrol/C. 310PF(J) 50WV (Vert. Type)	1
1-C55	EC666494	Styrol/C. 1500PF(K) 50WV (Vert. Type)	1
1-C58	EC621257	Solid Aluminum/C. 0.47 $\mu$ F(M) 25WV (Vert. Type)	1

## 2 MAIN AMP P.C BOARD (AA-5106A) BLOCK

Symbol No.	Parts No.	Description	Q'ty
2-1	BA211410	Main Amp P.C Board Comp. (AA-5106A)	1
2-TR1,2	ET459810	Transistor 2SC1222(E)(F)	4
2-TR3	ET655345	Transistor 2SB605(L)(M)	2
2-TR4	ET655356	Transistor 2SD571(L)(M)	2
2-TR5	ET655345	Transistor 2SB605(L)(M)	2
2-TR8	ET452531	Transistor 2SD313(E)(F)	1
2-D1	ED539976	Zener Diode WZ-130	1
2-D2,3	ED224548	Silicon Diode 10D2	2
2-V1	ED490511	Varistor VD1222	2
2-VR1	EV698264	2-axial 2-throw Vol. V24L5DGPHN 3BM250Kx2 (Friction-free)	1
2-VR2,3	EV698275	Co-axial 2-throw Vol. V16L GPHN-15C 20kx2	2
2-VR4	EV604484	Semi-fixed/Vol. V10K8-4-2 300B	2
2-J1	EJ698286	3P Jack	1
2-2	MZ656807	Jumper Wire, P.C Board 12.5mm	10
2-3	EJ539662	Wrapping Post 1x17	15
2-4	EJ514822	Fuse Holder, P.C Board S-N5051	4
2-C10	EC654153	Tantalum/C. 0.1 $\mu$ F(M) 25WV(DTS Type)	2
2-C12	EC523282	Solid Aluminum/C. 0.1 $\mu$ F(M) 25WV (Vert. Type)	2
2-C13	EC538244	Solid Aluminum/C. 0.47 $\mu$ F(M) 10WV (Vert. Type)	2
2-R24,25	ER552712	Metal Plate/R. MPC70F 2W 0.47 ohms (K)	4
2-R28	ER439132	Metal Oxide Film/R. 2W 150 ohms (K)	2

## 3 LED P.C BOARD (AA-5106B) BLOCK

Symbol No.	Parts No.	Description	Q'ty
3-1	BA681693	LED P.C Board Comp. (AA-5106B)	1
3-D1	ED694091	Luminous Diode SEL-105RC	1
3-2	MZ203095	Lamp Base	1
3-3	ZS422076	Screw, pan head 3x5	1

## 4 PEAKING COIL P.C BOARD (AA-5106C) BLOCK

Symbol	Parts No.	Description	Q'ty
4-1	BA681682	Peaking Coil P.C Board Comp. (AA-5106C)	1
4-L1	EO539820	Peaking Coil 2.2 $\mu$ H(K)	1

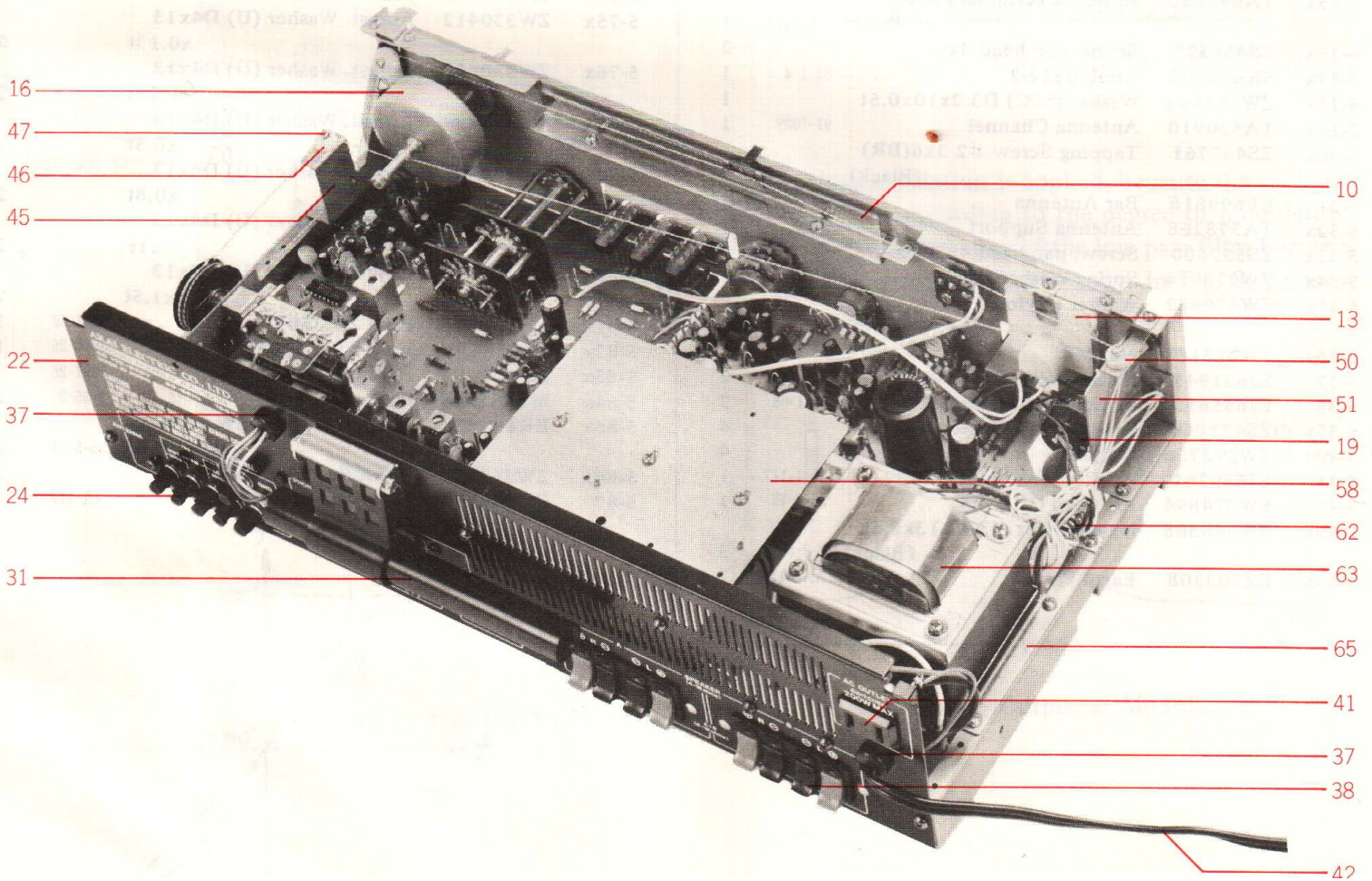
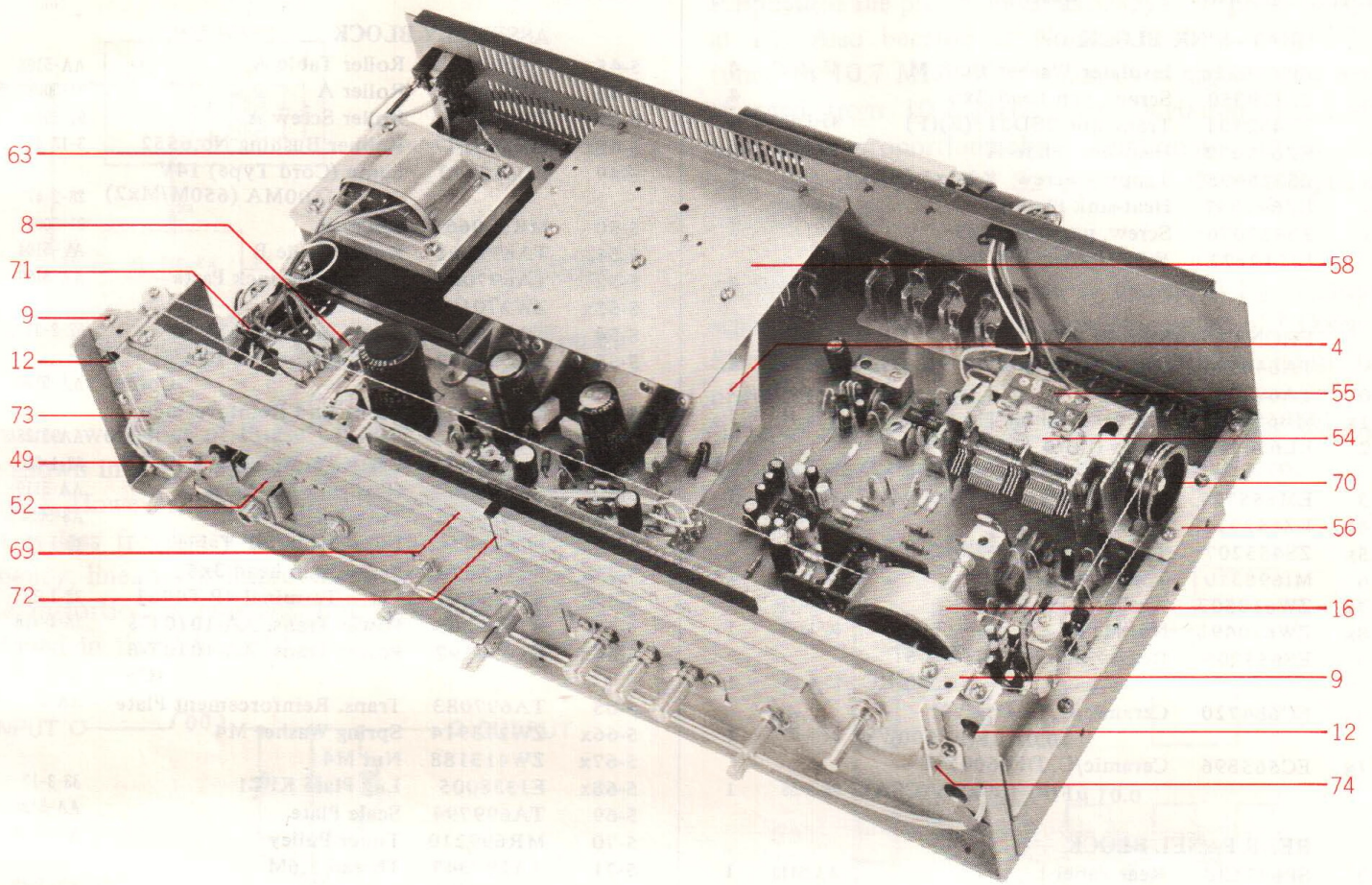

## 5) ASSEMBLY BLOCK

Ref. No.	Parts No.	Description	Schematic No.	Q'ty	Ref. No.	Parts No.	Description	Schematic No.	Q'ty
<b>HEAT-SINK BLOCK</b>					<b>ASSEMBLY BLOCK</b>				
5-1x	ZW632226	Insulator Washer Bush M	45-16-27	4	5-45	TA697094	Roller Table A	AA-5103	1
5-2x	ZS379350	Screw, pan head 3x6		4	5-46	MR530651	Roller A	91-5008	2
5-3x	ET452531	Transistor 2SD313(E)(F)	45-1-105	4	5-47	ZS530673	Roller Screw A	91-5010	4
5-4	EZ697072	Heat-sink Plate A	AA-5107	1	5-48x	MB650147	Rubber Bushing No.6552	3-13-44	2
5-5x	ZS325495	Tapping Screw #2 3x6 (BR)		31	5-49	EL650193	Lamp (Cord Type) 14V 100MA (650M/Mx2)	28-2-47	1
5-6x	EZ697037	Heat-sink Plate B	AA-5108	1	5-50	MR530662	Roller B	91-5009	2
5-7x	ZS422076	Screw, pan head 3x5		1	5-51	TA697061	Roller Table B	AA-5104	1
5-8	EJ514822	Fuse Holder, P.C Board S-N5051	40-1-28	4	5-52	TA697050	Headphone Jack Parts	AA-5109	1
<b>FRONT CHASSIS BLOCK</b>					<b>ASSEMBLY BLOCK</b>				
5-9	TA646571	Panel Support	AA-5218	2	5-53x	ZW270191	E Jack Nut		1
5-10	TA697048	Rail	AA-5117	1	5-54	TA655301	Front End FB512U13	57-2-35	1
5-11x	MB650147	Rubber Bushing No.6552	3-13-44	1	5-55	BA681682	Peaking Coil P.C Board		1
5-12	EL650158	Lamp (Cord Type) 14V 100MA (200M/Mx2)	28-2-48	2	5-56	MZ699772	Front End Reinforcement Plate	AA-5106C AA-5128	1
5-13	EM655727	Tuning Meter KL-218D-94	46-1-110	1	5-57x	EJ539447	Earth Terminal 2P T4460	32-1-32	1
5-14x	EZ652915	Meter Support	AA-5015	1	5-58	TA696104	Heat-sink Mt. Parts	AA-5110	1
5-15x	ZS455207	Tapping Screw #2 3x5 (BR)		1	5-59x	EZ610773	Fuse Angle A8	A8-5054	2
5-16	MI698310	Tuning Wheel	13-2-4	1	5-60x	EZ652410	Fuse Holder 3P Table	40-1-68	1
5-17x	ZW610503	Washer D11	36-13-2	1	5-61x	ZS422076	Screw, pan head 3x5		2
5-18x	ZW610492	Nut M11	36-13-3	1	5-62	EJ539436	Earth Terminal 4P T4461	32-1-30	1
5-19	ES655705	Rotary SW. SR26N 1-2-5 30 KC	25-6-85	1	5-63	BT699805	Power Trans. AA-1010T-5	38-4-418	1
5-20x	EC684720	Ceramic/C. CLD16YE 0.01 μF(P) 500WV	24-5-61	1	5-64x	BT698297	Power Trans. AA-1010T-6 (CSA)	38-4-419	1
5-21x	EC565896	Ceramic/C. DP6600YM 0.01 μF(P) 1.4 KWV(CSA)	24-5-58	1	5-65	TA697083	Trans. Reinforcement Plate	AA-5116	1
<b>REAR PANEL BLOCK</b>					<b>ASSEMBLY BLOCK</b>				
5-22	SP697138	Rear Panel 1	AA-5112	1	5-66x	ZW273914	Spring Washer M4		4
5-23x	SP697140	Rear Panel 2 (CSA)	AA-5112	1	5-67x	ZW413188	Nut M4		4
5-24	EZ655187	5P Antenna Terminal Plate	32-1-69	1	5-68x	EJ338005	Lug Plate KPL1	33-3-13	1
5-25x	TA698253	Antenna Terminal Plate Mt. Parts	AA-5115	1	5-69	TA699794	Scale Plate	AA-5125	1
5-26x	ZS355522	Screw, pan head 3x6		2	5-70	MR699210	Tuner Pulley	AA-5127	1
5-27x	SK652397	Knob 0512-2	34-1-4	1	5-71	TA207347	Thread 1.6M		1
5-28x	ZW652408	Washer (SPC) D3.2x10x0.5t		1	5-72	TA646795	Pointer	AA-5242	1
5-29x	TA530910	Antenna Channel	91-5029	1	5-73	TA697004	Scale Plate Retainer A	AA-5118	1
5-30x	ZS447761	Tapping Screw #2 3x6(BR) (Black)		3	5-74	TA697015	Scale Plate Retainer B	AA-5118	1
5-31	EF699816	Bar Antenna	55-1-32	1	5-75x	ZW330412	Adjust. Washer (U) D4x13 x0.13t		2
5-32x	TA378268	Antenna Support	AA-5552	1	5-76x	ZW330423	Adjust. Washer (U) D4x13 x0.25t		2
5-33x	ZS552600	Screw, pan head 4x50		1	5-77x	ZW330434	Adjust. Washer (U) D4x13 x0.5t		2
5-34x	ZW273914	Spring Washer M4		2	5-78x	ZW330445	Adjust. Washer (U) D4x13 x0.8t		2
5-35x	ZW420682	Washer (Nylon) D4.2x9 x0.5t		2	5-79x	ZW330456	Adjust. Washer (U) D4x13 x1t		2
5-36x	ZW413188	Nut M4		1	5-80x	ZW439547	Adjust. Washer (U) D4x13 x1.5t		2
5-37	EJ631945	Strain Relief SR-4N-4	2-7-49	2	5-81x	EF563703	Fuse 2A 250V	39-1-50	3
5-38	EJ655683	4P Speaker Terminal C	32-1-68	2	5-82x	EF424811	Fuse ST-2 2.5A (CSA)	39-1-26	1
5-39x	ZS421740	Screw, pan head 3x8		4	5-83x	EF277413	Fuse ST-2 2A (CSA)	39-1-26	3
5-40x	ZW273756	Nut M3		4	5-84x	MT553948	Wire Band B	2-35-3	3
5-41	EJ650261	AC Consent U/L S-16432	31-1-147	1	5-85x	ER669328	Solid/R. RCH 1/2W 2.2M(J) (CSA)	35-5-11	1
5-42	EW374894	AC Cord CUL 3M	26-3-19	1	5-86x	ZW562476	Earth Lug M3 (CSA)		1
5-43x	ZW698308	Nylon Rivet (FNPR) 3x5.5 (Black)	2-7-54	3	5-87	ZG200204	Dial Spring	AA-5133	1
5-44x	EZ203308	Earth Parts	AA-5126	1					

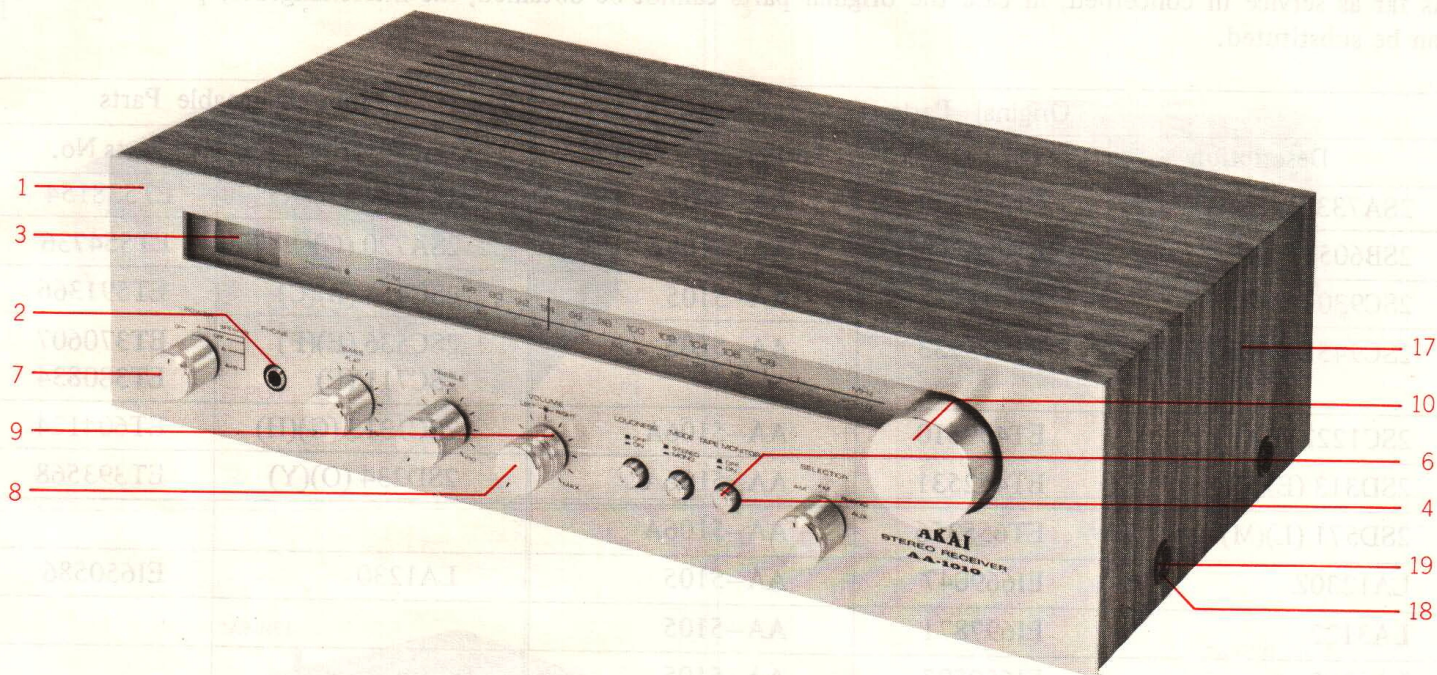

## 6) FINAL ASSEMBLY BLOCK

Ref. No.	Parts No.	Description	Schematic No.	Q'ty
<b>FRONT PANEL BLOCK</b>				
6-1	BD681636	Front Panel Block Comp.		1
6-2	ZW526577	Collar B, Jack	MC-5006	1
6-3	SP645715	Front Plate	AA-5245	1
6-4	SE613888	Button Escutcheon A	CW-6021	3
6-5x	SE699761	Light Mask	AA-5119	2
<b>ASSEMBLY BLOCK</b>				
6-6	SK634410	Push Button Knob J	91-5051	3
6-7	SK646817	Single Knob	AA-5250	4
6-8	SK644670	Double Knob (Upper)	AA-5355	1
6-9	SK645208	Double Knob (Lower)	AA-5353	2
6-10	SK646828	Tuning Knob (Small)	AA-5252	1
6-11x	ZS203343	Set Screw, hexagon socket 3x18 WP		1
6-12x	SP697116	Bottom Plate	AA-5122	1
6-13x	ZS325495	Tapping Screw #2 3x6 (BR)		5
6-14x	ZS447840	Tapping Screw #2 3x8 (BR)		1
6-15x	SZ645243	Circular Foot A, w/rubber A	CA-6014	4
6-16x	ZS565942	Tapping Screw #2 4x8 (PAN)		4
6-17	BC699783	Cabinet	AA-5123	1
6-18	ZW548010	Spot Facing Washer	MU-6028	4
6-19	ZS510344	Screw, binding head 4x12		4

## 7 LIST OF INTERCHANGEABLE SEMICONDUCTORS

As far as service is concerned, in case the original parts cannot be obtained, the interchangeable parts listed below can be substituted.

Original Parts			Interchangeable Parts	
Description	Parts No.	Utilizing P.C Board	Description	Parts No.
2SA733(P)(Q)(R)	ET539122	AA-5005	2SA564 (Q)(R)	ET538154
2SB605 (L)(M)	ET655345	AA-5106A	2SA720 (Q)(R)	ET554736
2SC930 (E)(F)	ET618873	AA-5105	2SC454 (B)(C)	ET591366
2SC945L (P)(Q)(R)(S)	ET515733	AA-5105	2SC536 (E)(F)	ET370607
			2SC711 (E)	ET380834
2SC1222 (E)(F)	ET459810	AA-5106A	2SC1313 (G)(H)	ET604124
2SD313 (E)(F)	ET452531	AA-5106A	2SD234 (O)(Y)	ET393568
2SD571 (L)(M)	ET655356	AA-5106A		
LA1230Z	EI669047	AA-5105	LA1230	EI650586
LA3122	EI697871	AA-5105		
LA3350	EI650597	AA-5105		
$\mu$ PC30C	EI650362	AA-5105		
1S2473	ED624903	AA-5105	1S1588	ED557447
			WG711	ED515990
			WG599	ED514721
10D2	ED224548	AA-5106A	1N4003	ED570295
VD1222	ED490511	AA-5106A		
WZ130	ED539976	AA-5106A		
SEL105RC	ED694091	AA-5106B		

# INDEX

Parts No.	Ref. No. & Symbol No.	Parts No.	Ref. No. 7 Symbol No.	Parts No.	Ref. No. & Symbol No.	Parts No.	Ref. No. & Symbol No.	Parts No.	Ref. No. & Symbol No.
BA211397	1-1	EZ652915	5-14x	ZW652408	5-28x				
BA211410	2-1	EZ655187	5-24	ZW698308	5-43x				
BA681682	4-1	EZ697037	5-6x						
BA681682	5-55	EZ697072	5-4						
BA681693	3-1	MB650147	5-11x						
BC699783	6-17	MB650147	5-48x						
BD681636	6-1	MI698310	5-16						
BT697950	1-T2	MR530651	5-46						
BT698297	5-64x	MR530662	5-50						
BT699805	5-63	MR699210	5-70						
EC523282	2-C12	MT553948	5-84x						
EC538244	2-C43	MZ203095	3-2						
EC565896	5-21x	MZ656807	1-3						
EC621257	1-C58	MZ656807	2-2						
EC650406	1-C40	MZ699772	5-56						
EC654153	2-C10	SE613888	6-4						
EC666494	1-C55	SE699761	6-5x						
EC684720	5-20x	SK634410	6-6						
ED224548	2-2C, 3	SK644670	6-8						
ED490511	2-V1	SK645208	6-9						
ED539976	2-D1	SK646817	6-7						
ED624903	1-D1, 2	SK646828	6-10						
ED694091	3-D1	SK652397	5-27x						
EF277413	5-83x	SP645715	6-3						
EF424811	5-82x	SP697116	6-12x						
EF563703	5-81x	SP697138	5-22						
EF699816	5-31	SP697140	5-23x						
EI650362	1-IC3	SZ645243	6-15x						
EI650597	1-IC4	TA207347	5-71						
EI669047	1-IC1	TA378268	5-32x						
EI697871	1-IC2	TA530910	5-29x						
EJ338005	5-68x	TA646571	5-9						
EJ514822	2-4	TA646795	5-72						
EJ514822	5-8	TA655301	5-54						
EJ539436	5-62	TA696104	5-58						
EJ539447	5-57x	TA697004	5-73						
EJ539662	1-2	TA697015	5-74						
EJ539662	2-3	TA697048	5-10						
EJ631945	5-37	TA697050	5-52						
EJ650261	5-41	TA697061	5-51						
EJ655334	1-J1	TA697083	5-65						
EJ655683	5-38	TA697094	5-45						
EJ698051	1-J2	TA698253	5-25x						
EJ698286	2-J1	TA699794	5-69						
EL650158	5-12	ZG200204	5-87						
EL650193	5-49	ZS203343	6-11x						
EM655727	5-13	ZS325495	5-5x						
EO539820	1-L1	ZS325495	6-13x						
EO539820	4-L1	ZS355522	5-26x						
EO650373	1-T4	ZS379350	5-2x						
EO650395	1-T3	ZS421740	5-39x						
EO650428	1-L3, 4	ZS422076	3-3						
EO650608	1-T1	ZS422076	5-7x						
EO650610	1-L2	ZS422076	5-61x						
ER439132	2-R28	ZS447761	5-30x						
ER552712	2-R24, 25	ZS447840	6-14x						
ER650430	1-FL1, 2	ZS455207	5-15x						
ER669328	5-85x	ZS510344	6-19						
ES655705	5-19	ZS530673	5-47						
ES697926	1-SW1	ZS552600	5-33x						
ES697937	1-SW2	ZS565942	6-16x						
ET452531	2-TR8	ZW270191	5-53x						
ET452531	5-3x	ZW273756	5-40x						
ET459810	2-TR1, 2	ZW273914	5-34x						
ET515733	1-TR2	ZW273914	5-66x						
ET515733	1-TR4	ZW330412	5-75x						
ET539122	1-TR3	ZW330423	5-76x						
ET618873	1-TR1	ZW330434	5-77x						
ET655345	2-TR3	ZW330445	5-78x						
ET655345	2-TR5	ZW330456	5-79x						
ET655356	2-TR4	ZW413188	5-36x						
EV484863	1-VR2	ZW413188	5-67x						
EV499364	1-VR1	ZW420682	5-35x						
EV604484	2-VR4	ZW439547	5-80x						
EV698264	2-VR1	ZW526577	6-2						
EV698275	2-VR2, 3	ZW548010	6-18						
EW374894	5-42	ZW562476	5-86x						
EZ203308	5-44x	ZW610492	5-18x						
EZ610773	5-59x	ZW610503	5-17x						
EZ652410	5-60x	ZW632226	5-1x						



**PEAKING COIL PC BOARD  
AA-5106C**  
(LOCATED ON FRONT END)

**MULTI FUNCTION PC BOARD AA-5105**

**LED PC BOARD  
AA-5106B**

**MAIN AMP PC BOARD AA-5106A**

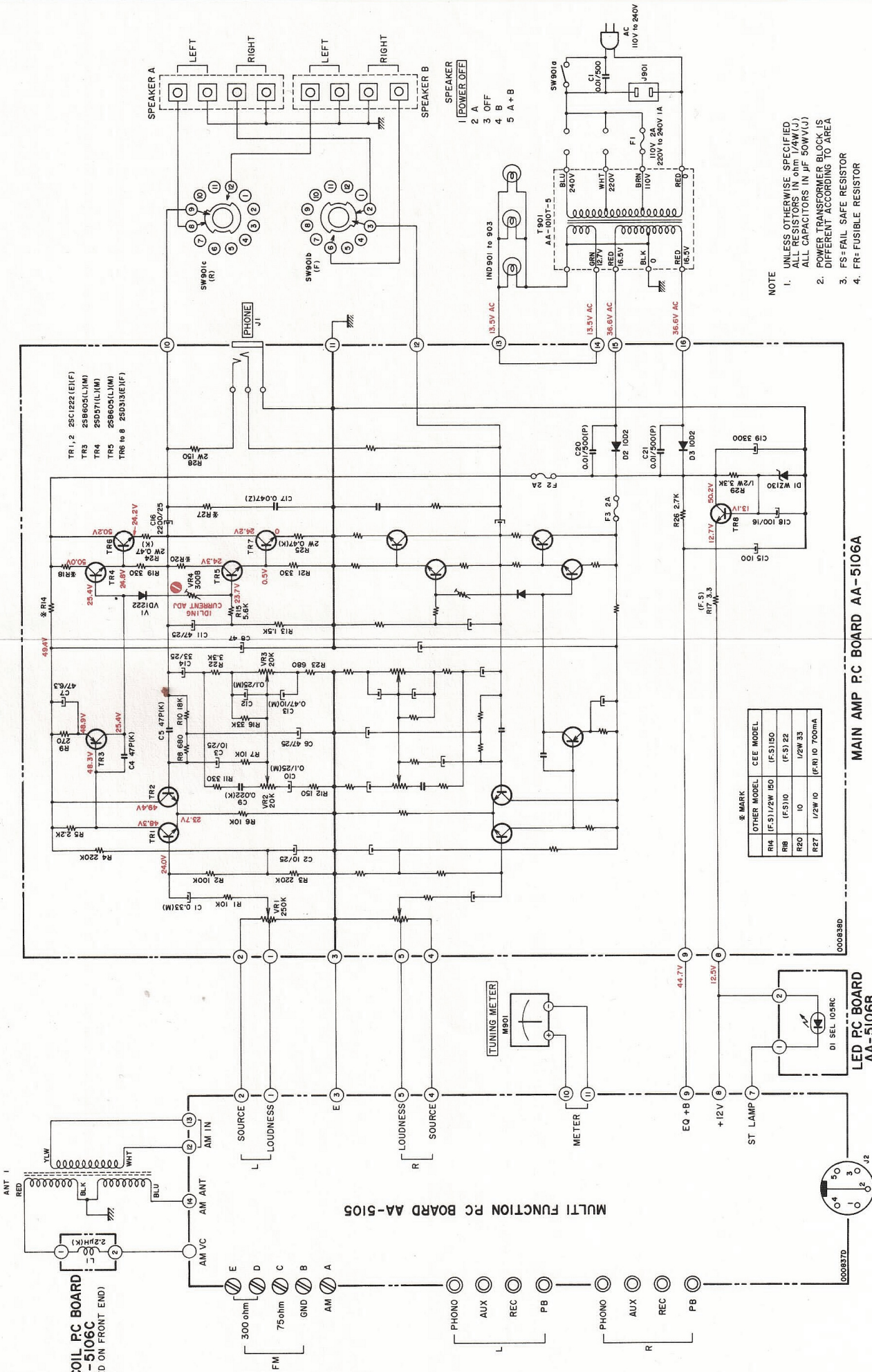

⊗ MARK

OTHER MODEL	SEE MODEL
R14 (F5) 1/2W 100	(F5) 150
R18 (F5) 10	(F5) 22
R20 10	1/2W 33
R27 1/2W 10	(FR) 10 700mA

- NOTE
- UNLESS OTHERWISE SPECIFIED ALL RESISTORS IN ohm I/AW (J) ALL CAPACITORS IN uF 50WV (J)
  - POWER TRANSFORMER BLOCK IS DIFFERENT ACCORDING TO AREA
  - FS = FAIL SAFE RESISTOR
  - FR = FUSIBLE RESISTOR

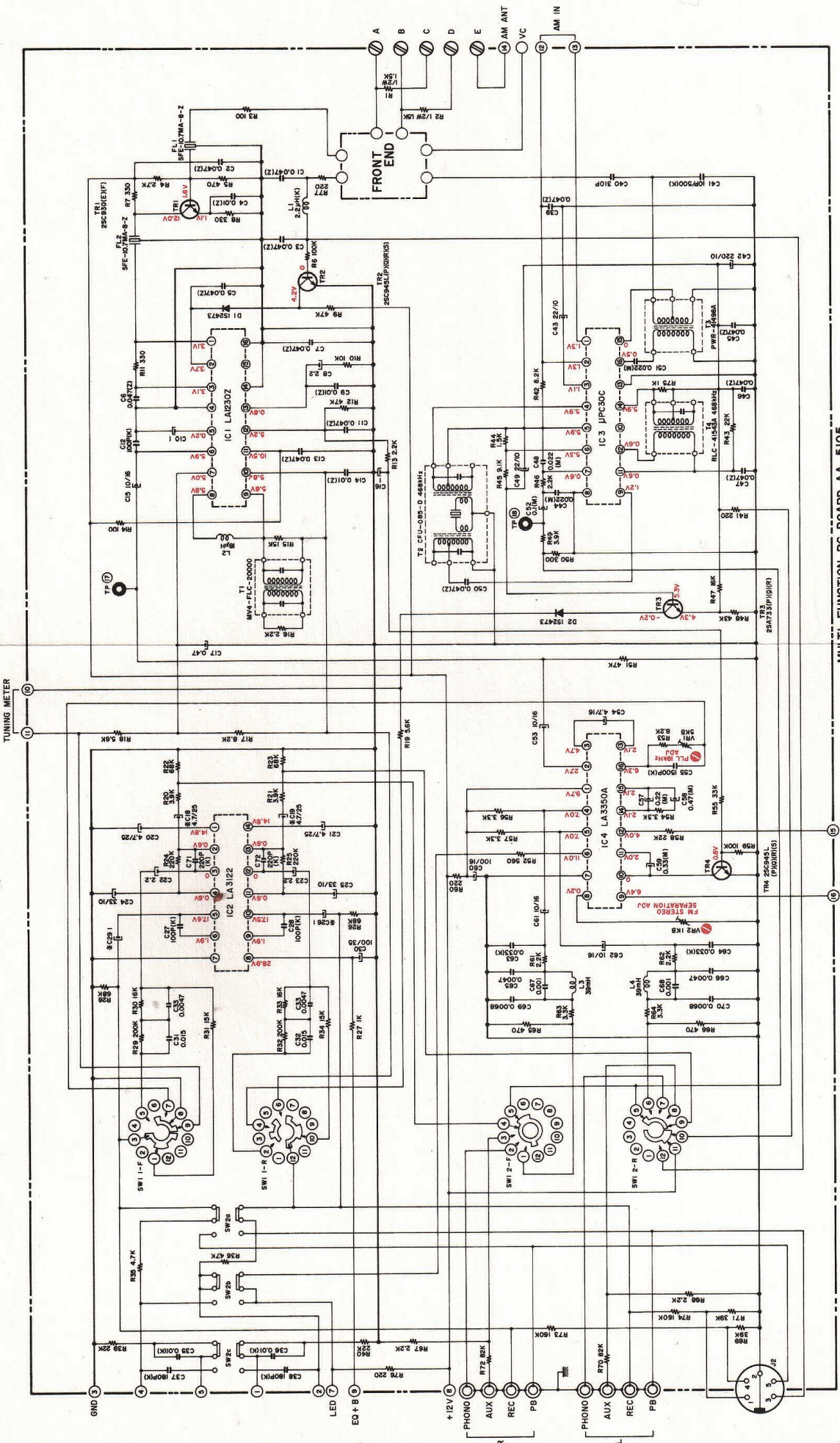

MULTI FUNCTION PC BOARD AA-5105

- SWITCH POSITIONS
- SW1 (SELECTOR)
    - (1) AM
    - (2) FM
    - (3) PHONO
    - (4) AUX
  - SW2a (TAPE MONITOR)
    - (OFF)
    - (MON)
    - (OFF)
  - SW2b (LOUDNESS)
    - (OFF)
    - (OFF)

NOTE  
 1 UNLESS OTHERWISE SPECIFIED  
 ALL RESISTORS ohms 1/4W(1)  
 ALL CAPACITORS IN uF 50WV(1)  
 2 \* MARK INDICATES LOW LEAKAGE CAPACITORS

AA-1010

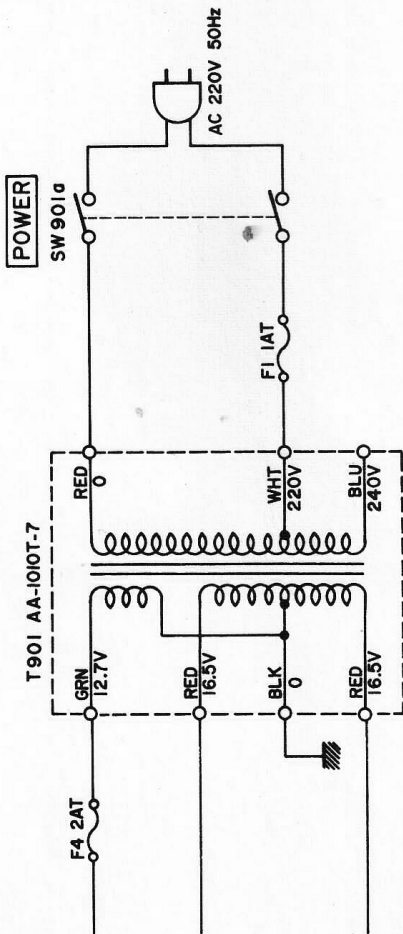

CEE

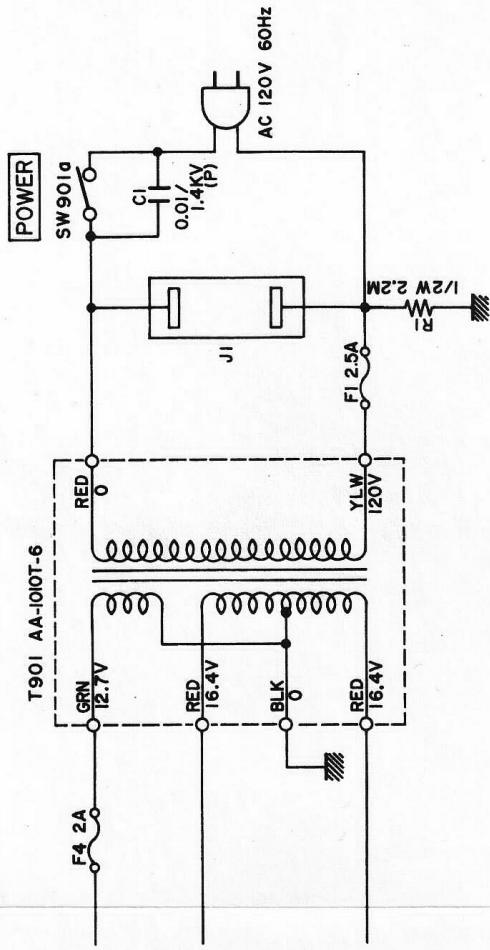

CSA

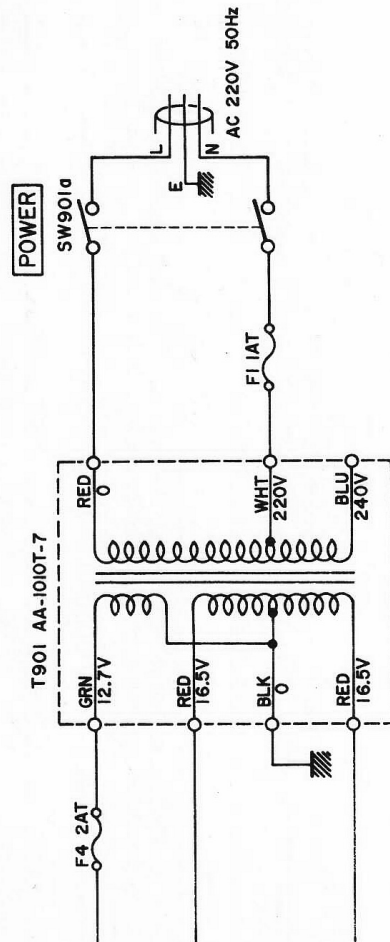

BEAB

NOTE  
POWER TRANSFORMER BLOCK IS  
DIFFERENT ACCORDING TO AREA

AA-1010  
POWER SUPPLY  
SCHEMATIC DIAGRAM  
NO.3-3 1521204A