



SEMI-AUTOMATIC TURNTABLE

MODEL AP-002

ALSO APPLICABLE TO MODEL AP-002D

I. SPECIFICATIONS

MODEL	AP-002	AP-002D
1. TYPE	Belt drive, automatic return	Belt drive, automatic return
2. CARTRIDGE	M.M type, APC-2 (VM)	M75B/2
3. OUTPUT VOLTAGE	2.2 to 4.4 mV, 1000 Hz, 50 mm/sec	2.2 to 6.0 mV 1000 Hz, 50 mm/sec
4. FREQUENCY RESPONSE	20 Hz to 25,000 Hz	20 Hz to 20,000 Hz
5. CROSS TALK	Better than 15 dB, 1,000 Hz	Better than 17 dB, 1,000 Hz
6. OUTPUT BALANCE	Within 3 dB	Within 2.5 dB
7. COMPLIANCE	5 to 8×10^{-6} cm/dyne	20×10^{-6} cm/dyne
8. STYLUS PRESSURE	2.5 gr \pm 15%	2.5 gr \pm 15%
9. STYLUS TIP	0.5 mil diamond tip (APN-2)	0.6 mil diamond tip (N75B/2)
10. TONE ARM	Static balanced type tubular arm with inside force canceller and lateral balance weight	Static balanced type tubular arm with inside force canceller and lateral balance weight
11. MOTOR	4-pole synchronous motor	4-pole synchronous motor
12. TURNTABLE	300 mm aluminum alloy diecast	300 mm aluminum alloy diecast
13. REVOLUTIONS	33-1/3, 45 r.p.m.	33-1/3, 45 r.p.m.
14. WOW & FLUTTER	Less than 0.15%	Less than 0.15%
15. S/N RATIO	Better than 30 dB	Better than 30 dB
16. POWER CONSUMPTION	Less than 17W	Less than 17W
17. DIMENSIONS	442(W)x185(H)x377(D)mm (17.4"x7.3"x14.8")	503(W)x185(H)x410(D)mm (19.8"x7.3"x16.1")
18. WEIGHT	7 kg (15.4 lbs.)	8 kg (17.6 lbs.)

In case of trouble, etc. necessitating disassembly, please disassemble in the order shown in photographs. Re-assemble in reverse order.

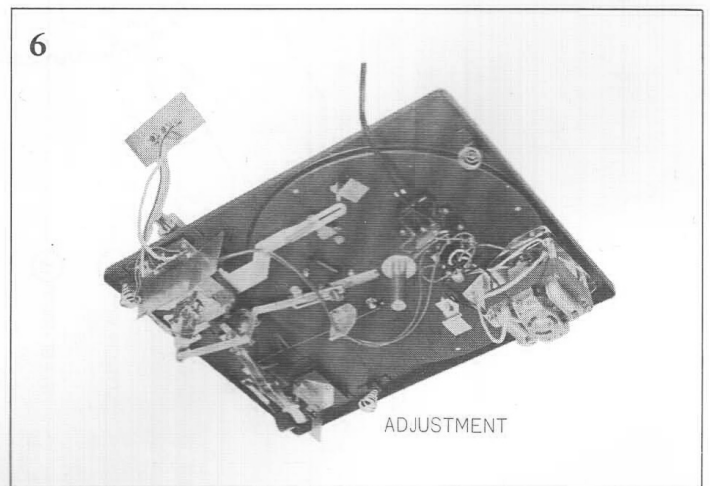
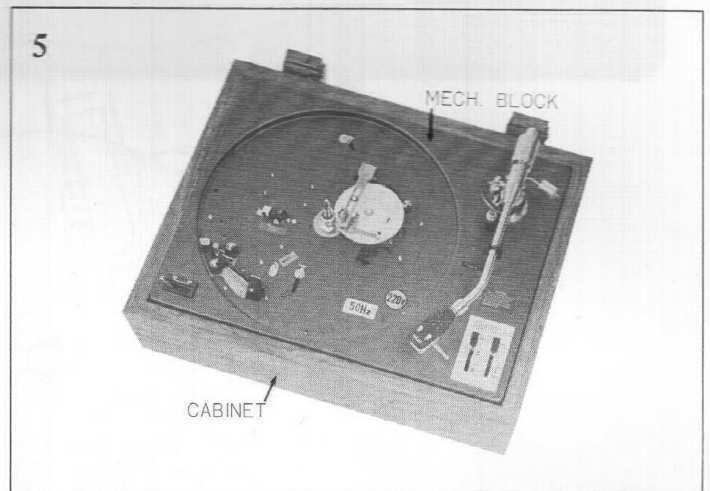
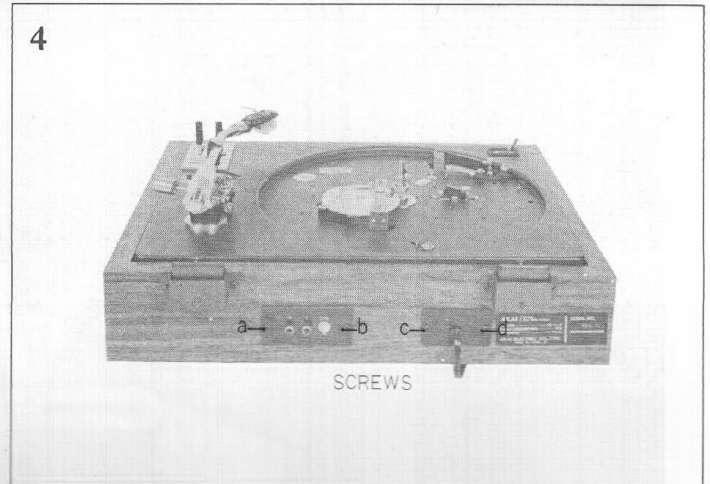
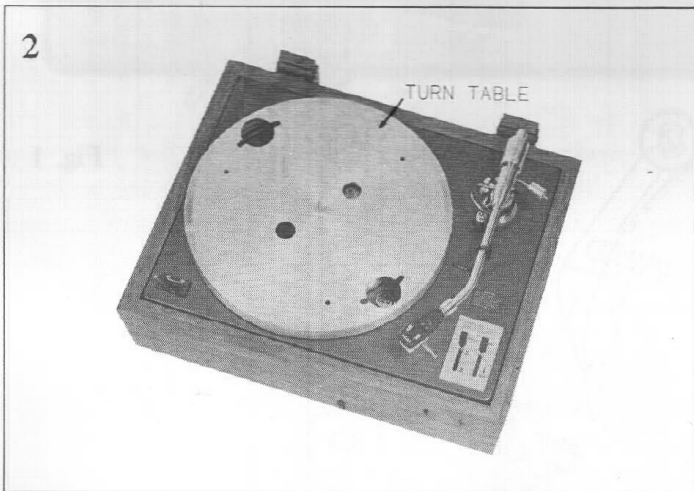
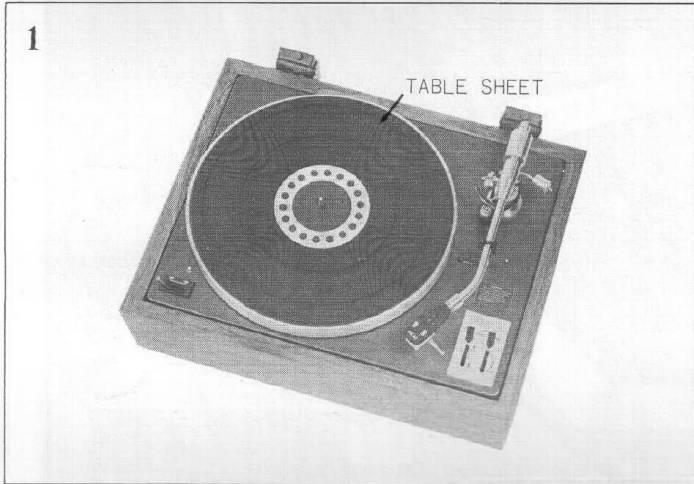

III. AUTOMATIC RETURN MECHANISM

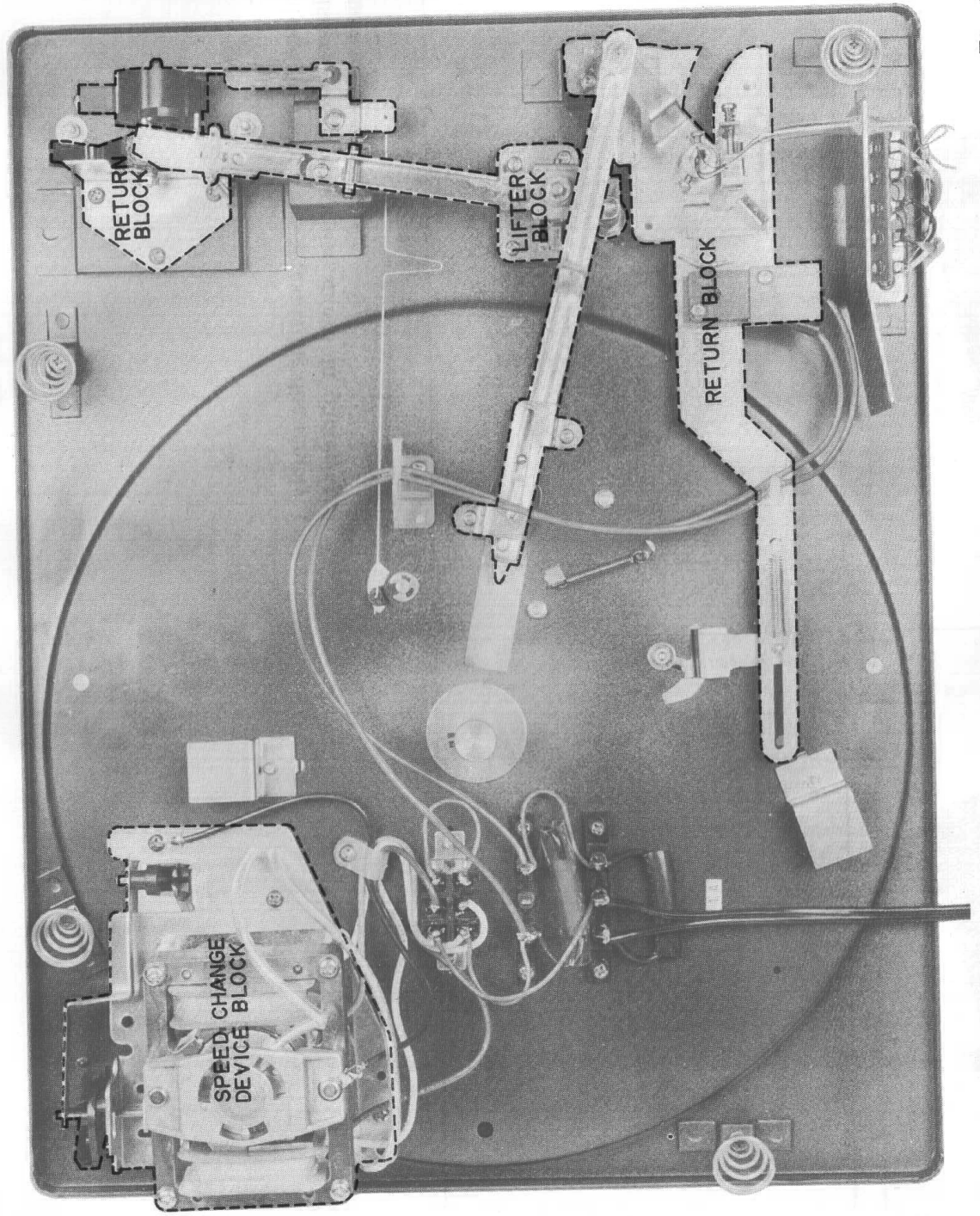
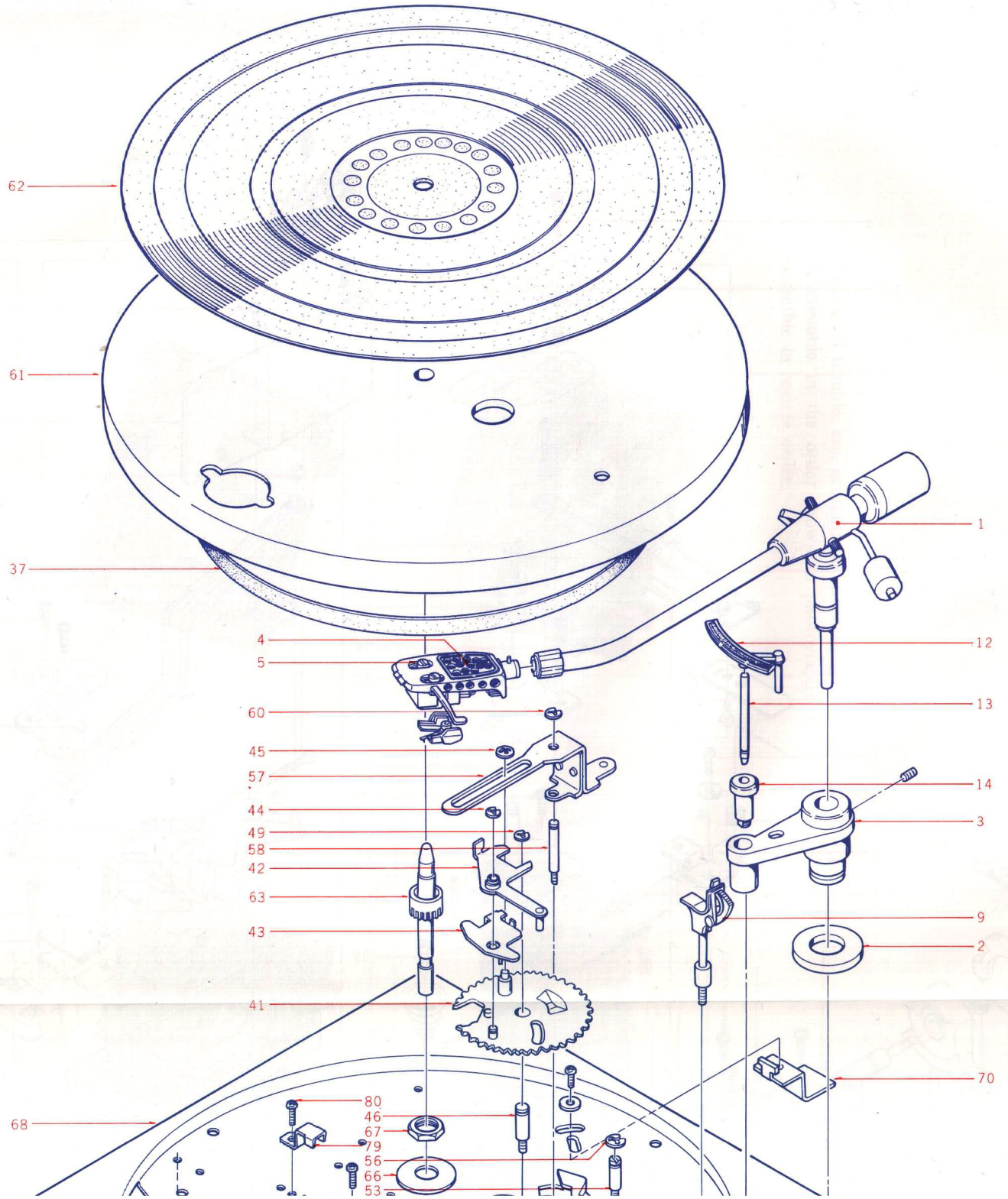
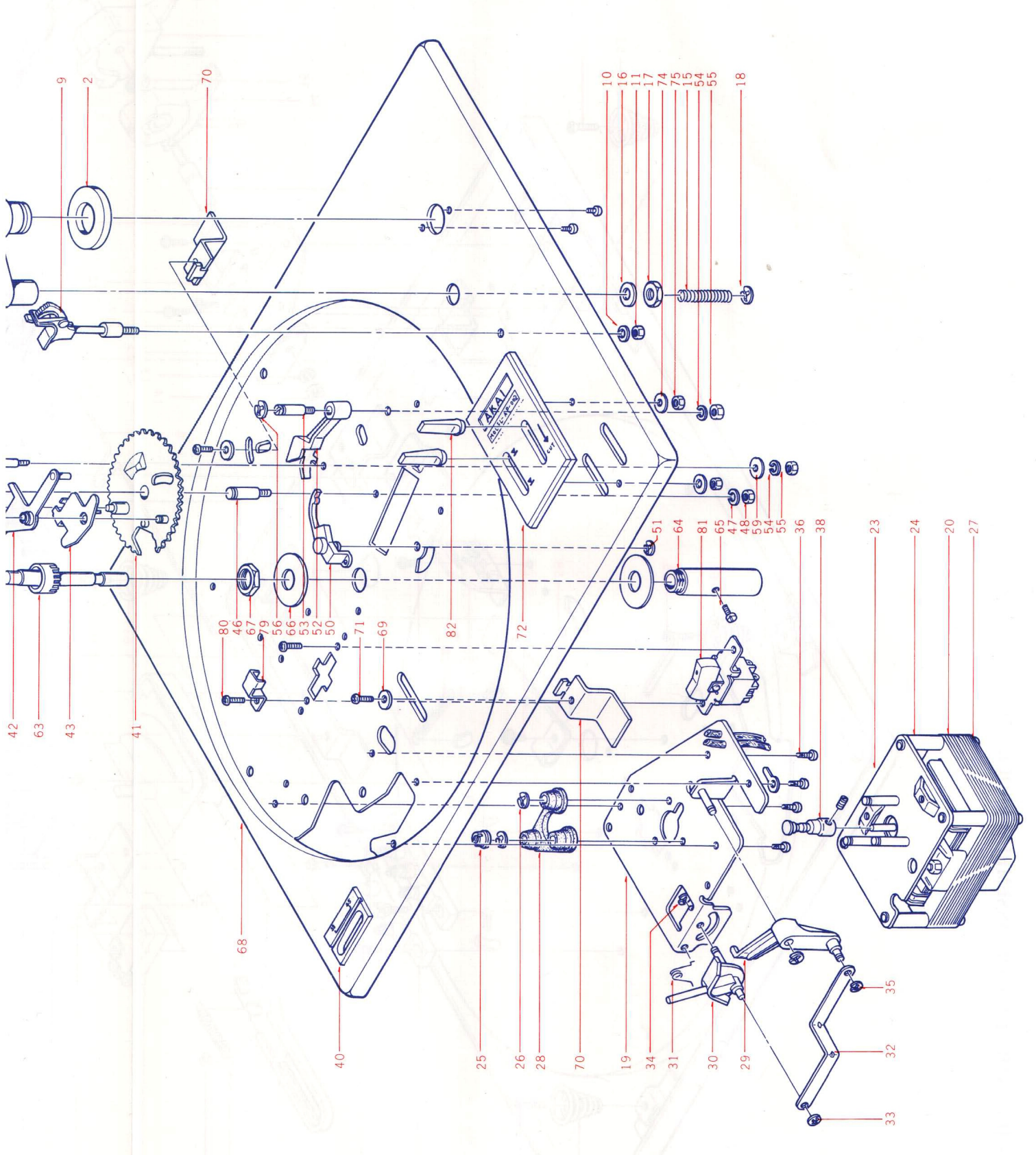

Fig. 1

TRATION OF ASSEMBLY BLOCK (1)





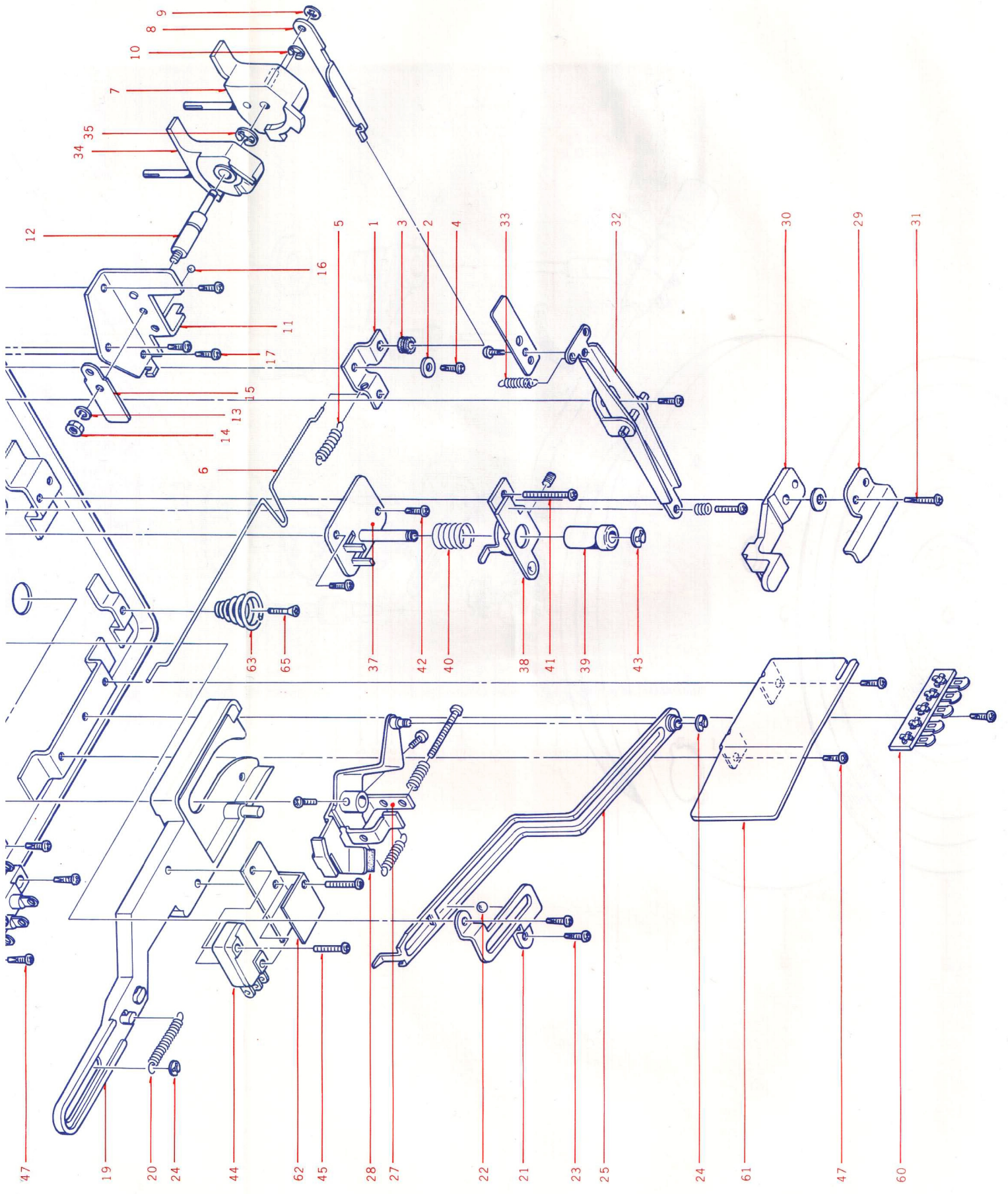
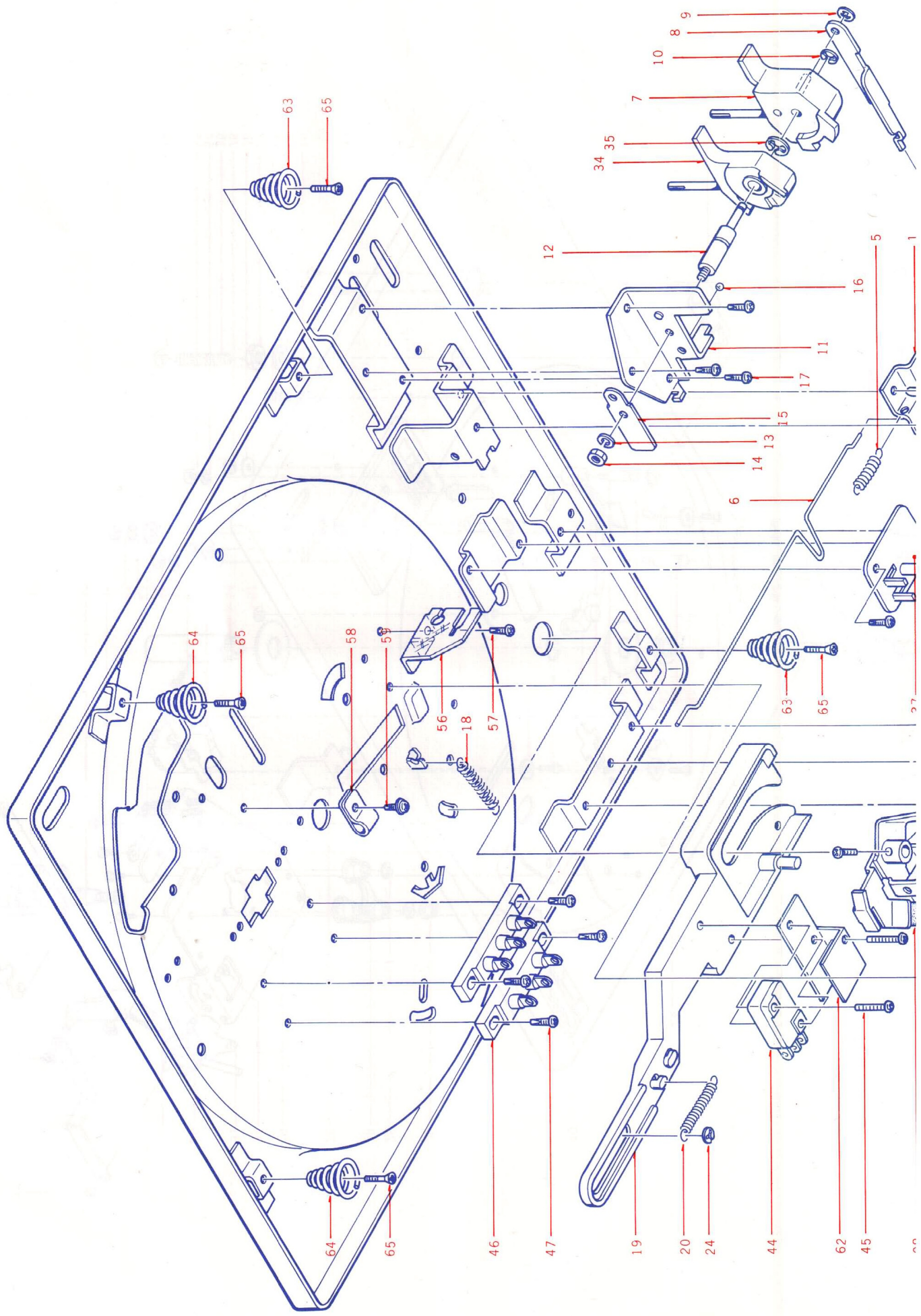
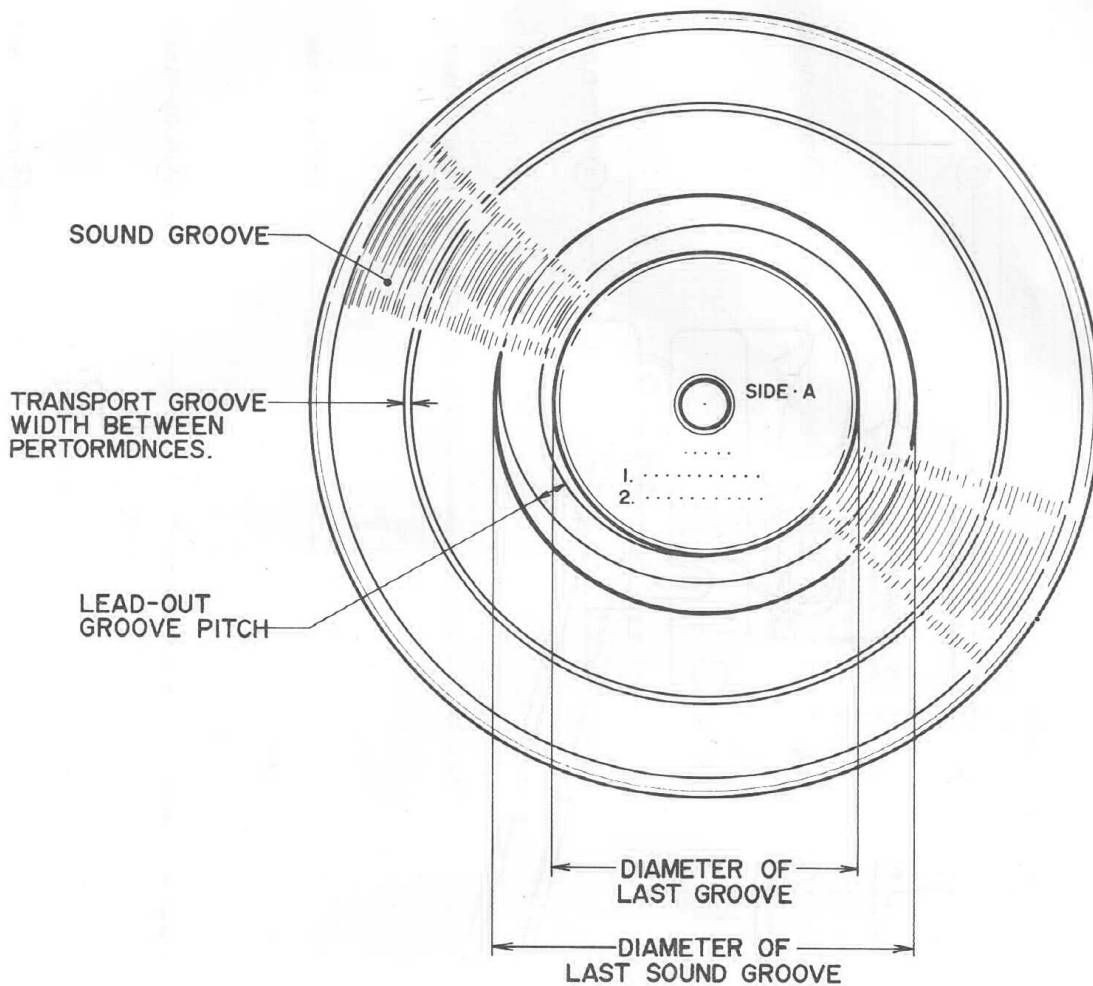

FIG. 2 ILLUSTRATION OF ASSEMBLY BLOCK (2)





The return mechanism of this machine is as shown in Fig. 2. Because of the use of "speed displacement type" perception equipment, when the program (performance) ends, and the pick up needle advances in lead-out groove, the perception equipment operates regardless of disc size (in case of JIS specification equivalent). That is to say that because the speed displacement type perception equipment operates with 100% certainty, the proper type of record becomes important. There are several different specifications. For instance, domestic JIS, and foreign IEC, RIAA, etc., but this machine is designed to operate as per JIS specifications. Below is a summary of JIS record dimensions necessary for automatic return.

- Transport groove: If transport groove diameter is within 230 mm, and this pitch or transport width is within 1 mm.
- Lead-out groove: Lead-out groove pitch is 4 to 9 mm and linkage is made to the last groove at more than one revolution.
- Last groove: Last groove is always linked from lead-out groove at concentric circle.

RECORD TYPE HEADING	17 cm 45 r.p.m.	17 cm 33 r.p.m.	25 cm	30 cm
Last Sound Groove Diameter	More than 106	More than 106	More than 115.2	More than 115.2
Last Groove Diameter	97±1	97±1	106.4±0.8	106.4±0.8

A gear the same as the pitch of MAIN GEAR (3) is installed to the SHAFT TABLE ASSY (1) and here a plectrum-like part projects from this part. Because this plectrum is for the purpose of picking up the timing of CLUTCH-ASSY (4) installed on the MAIN-GEAR (3) it rotates with the turntable during record performance. AUTO LEVER (9) is linked to the PLATE-PU-ASSY (10) which is directly connected to the pick up arm, and TRIP (5) begins to be pressed from about the time stylus tip reaches the lead-out groove. The movement of this AUTO-LEVER (9) is about 1/6 in relation to the movement of the stylus tip.

RETURN LEVER (11) is linked to MAIN GEAR (3) by CRANK LEVER ASSY (13) and reciprocal motion is in accordance with MAIN GEAR (3) revolutions. Then at the // slanted portion (hatching), PLATE ELEVATOR (16) is raised and the lifter (at ⊗ mark position) is elevated and the arm returned to the arm rest. Further, because current ON-OFF switch MINI-SW (12) is installed on RETURN LEVER (11), this switch operates to automatically stop turn table rotation when the pick up arm is returned to the arm rest. Because STOPPER GEAR (7) controls the revolving motion of MAIN GEAR (3), it operates to stop rotation so that the tooth gap part comes to a standstill at an established position near TABLE SHAFT ASSY (1).

Also in case the record is stopped during performance, PLATE JOINT (13), PLATE REJECT (14) and POLE REJECT (15) are intervened by the forward motion of CAM REJECT LEVER, PLATE REJECT (2) operates, and CLUTCH ASSY (4) is pushed out.

1. AUTOMATIC RETURN

As shown in Fig. 3 when the pick up arm moves to the record surface, the PLATE-PU ASSY (10) which is directly connected to the arm shaft separates from MINI SW (12), power source is turned ON, and the turntable rotates. As the pick up stylus tip traces the recorded groove of the record, AUTO LEVER (9) also advances on the inner side proportionately. Because this AUTO LEVER advances as the STEEL BALL (17) on HOLDER BALL (8) rolls, movement is extremely smooth and there is almost no influence extended to pick up arm side pressure.

In due time the pick up stylus finishes sound groove tracing and about the time it enters the lead-out groove, the tip of AUTO-LEVER (9) begins to push the skirt part of TRIP (5) and the CLUTCH ASSY (4) which rides lightly on this part is pushed out toward the TABLE SHAFT ASSY (1) (shown in Fig. 5, when the pick up stylus is at a about 126 mm position from the turntable).

At this condition, the protruding part of the gear on TABLE SHAFT ASSY (1) is drawn to CLUTCH ASSY (4) and the MAIN GEAR begins to rotate (Fig. 6). Up to now MAIN GEAR (3) had been held at a standstill by STOPPER GEAR (7) and a smooth stop effected by the teeth gap, but when the condition in Fig. 6 is assumed the teeth begin to mesh together and rotating motion begins. Then as shown in Fig. 7, this motion by means of CRANK LEVER ASSY (6) moves RETURN LEVER (11) in the direction of the arrow, and PLATE ELEVATOR (16) is raised and the lifter is elevated. When pick up arm elevation is complete, as shown in Fig. 8, the part indicated by broken line of RETURN LEVER (11) hits the cushion part attached to the tip of PLATE PU ASSY (10) and pick up arm return commences. When the pick up arm returns to the rest, the RETURN LEVER (11) by means of CRANK LEVER (6) moves in the opposite direction (broken arrow mark), PLATE PU ASSY (10) returns to former position, and in due course approaching MINI SW (12) is operated and the power source is turned OFF so that the condition in Fig. 3 is re-assumed.

2. INOPERATIVE PITCH

As can be seen by the JIS specification summary above, record sizes entail 3 kinds of specifications, and these are classified into 2 categories which are directly related to automatic return. These are 17 cm and 25/30 cm dimensions. For perception of return position of these two kinds of records, in the case of inoperative part of gear (less than 1 mm) the operating principle of the perception equipment is as follows: On a 17 cm record the last sound groove trace is in the vicinity of 110^ϕ .

However, on a 30 cm record the sound groove has already ended at the vicinity of 110^ϕ and the stylus has passed the lead-out groove and is moving to the last groove (concentric circle) at about this time (1.8 mm radius).

Therefore, when the pick up arm comes to this vicinity, if it is a 30 cm record, return operation must commence, and if it is a 17 cm record, the last trace must yet be effected. The difference in circumstances of these two records lie in the volume of movement of the stylus advancement within one single revolution. In the case of a 17 cm record, because this pitch is very limited (less than 1 mm), it is satisfactory if the CLUTCH ASSY is kicked back by the protruding part of the TABLE SHAFT ASSY as shown in Fig. 10 each time the record makes one revolution.

For details of this kicked back condition, refer to Fig. 11. The gamma (γ) (kick back volume) is about 0.6 m/m and on a 17 cm record even with a transport pitch of 1 mm, the CLUTCH ASSY cannot retrieve this kicked back portion.

Regardless of how many times the record rotates, the transport pitch is less than 1 mm and the clutch assembly continues to be kicked back. (Fig. 12) (Even if the record is traced to about 97^ϕ vicinity (outside of specifications), if the transport pitch is less than 1 mm, return will definitely not be effected during the performance), (this occurs only when the TRIP is pushed).

However, because practically all marketed records are JIS or equivalent, when the stylus advances to about 106^ϕ vicinity and moves to the lead-out groove, the transport pitch suddenly increases (4 to 9 mm). When this happens, the CLUTCH ASSY movement which to now could not retrieve the 0.6 mm kick back volume suddenly is increased (over 1.2 mm), and on the next revolution when the protruding part approaches, meshing takes place and return begins.

In this manner the "speed displacement type return mechanism utilizes the operating pitch and regardless of whether the record is 17 cm or 30 cm, return is effected at the end of record performance.

3. FORCE (MANUAL) CUT

When listening to a record and you wish to stop in the middle of a performance, or when playing a record not according to specifications, and the stylus tip has advanced to the last groove, simply bring the cut lever forward. This moves PLATE REJECT 2 which pushes PLATE JOINT (13), then POLE REJECT (15) and ultimately CLUTCH ASSY (4) is pushed as shown in Fig. 13. (\Leftarrow mark). Then return operation commences and the power source is turned OFF (Refer to Item 1 above and Fig. 5).

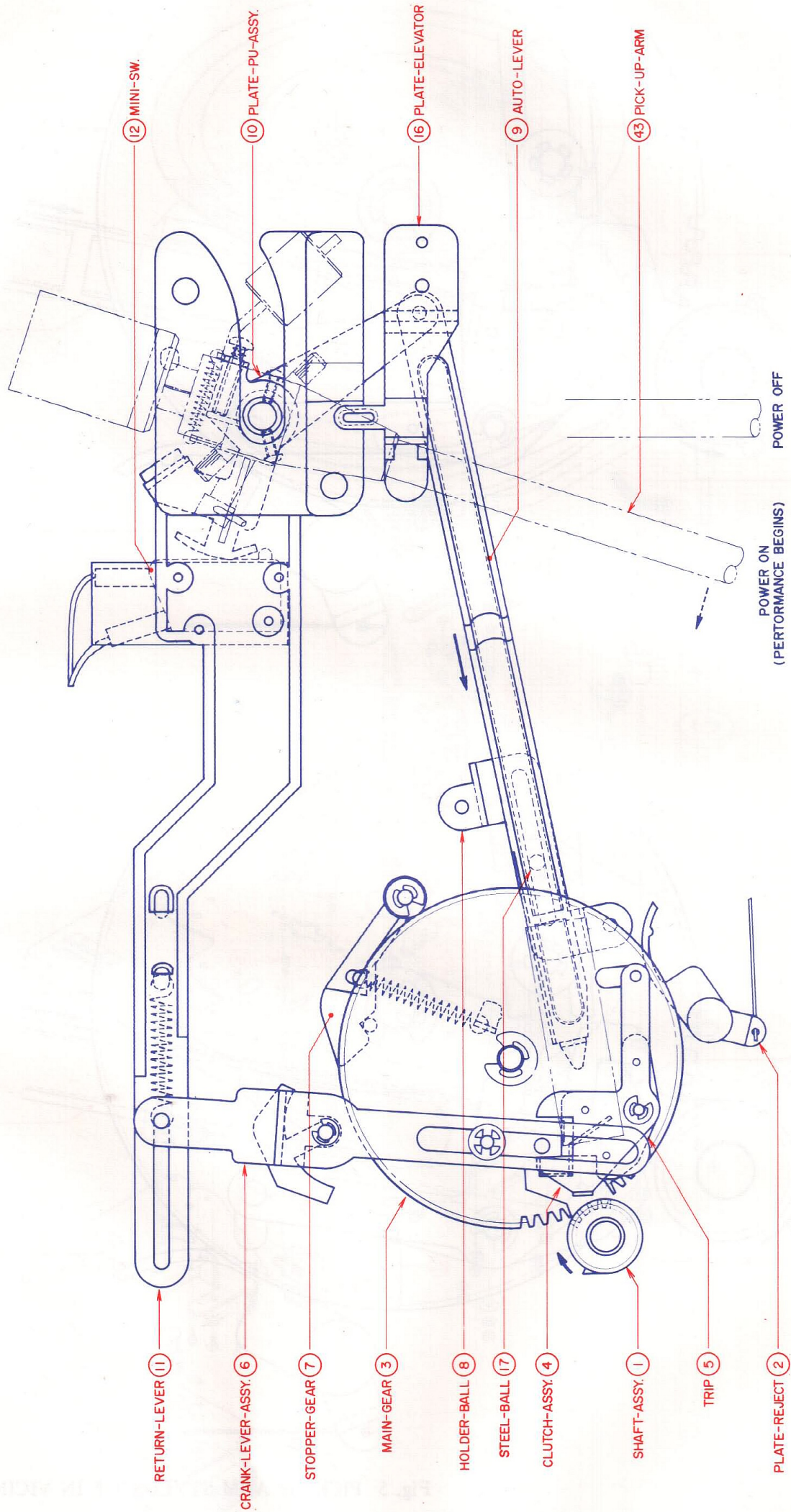
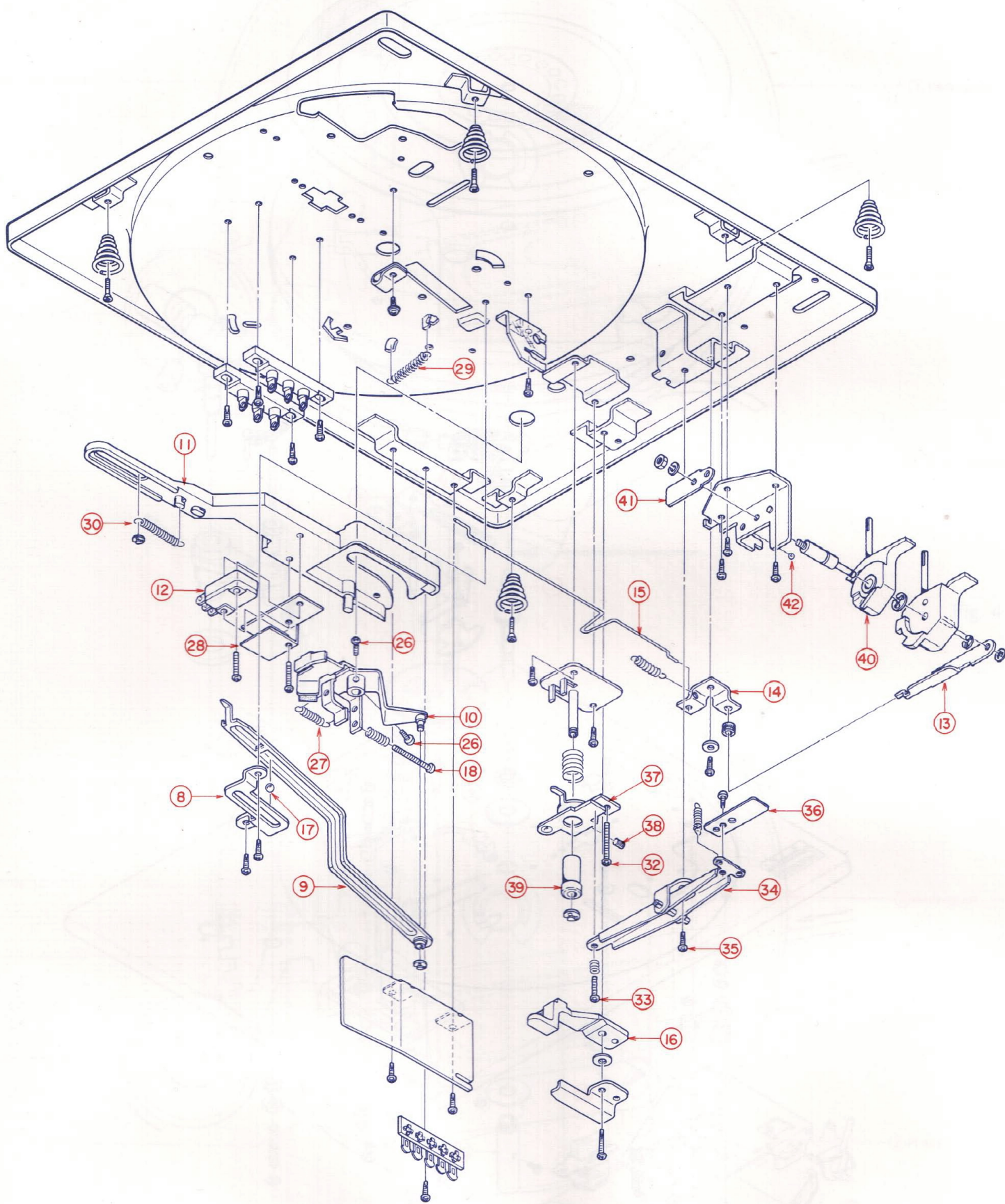

Fig. 3



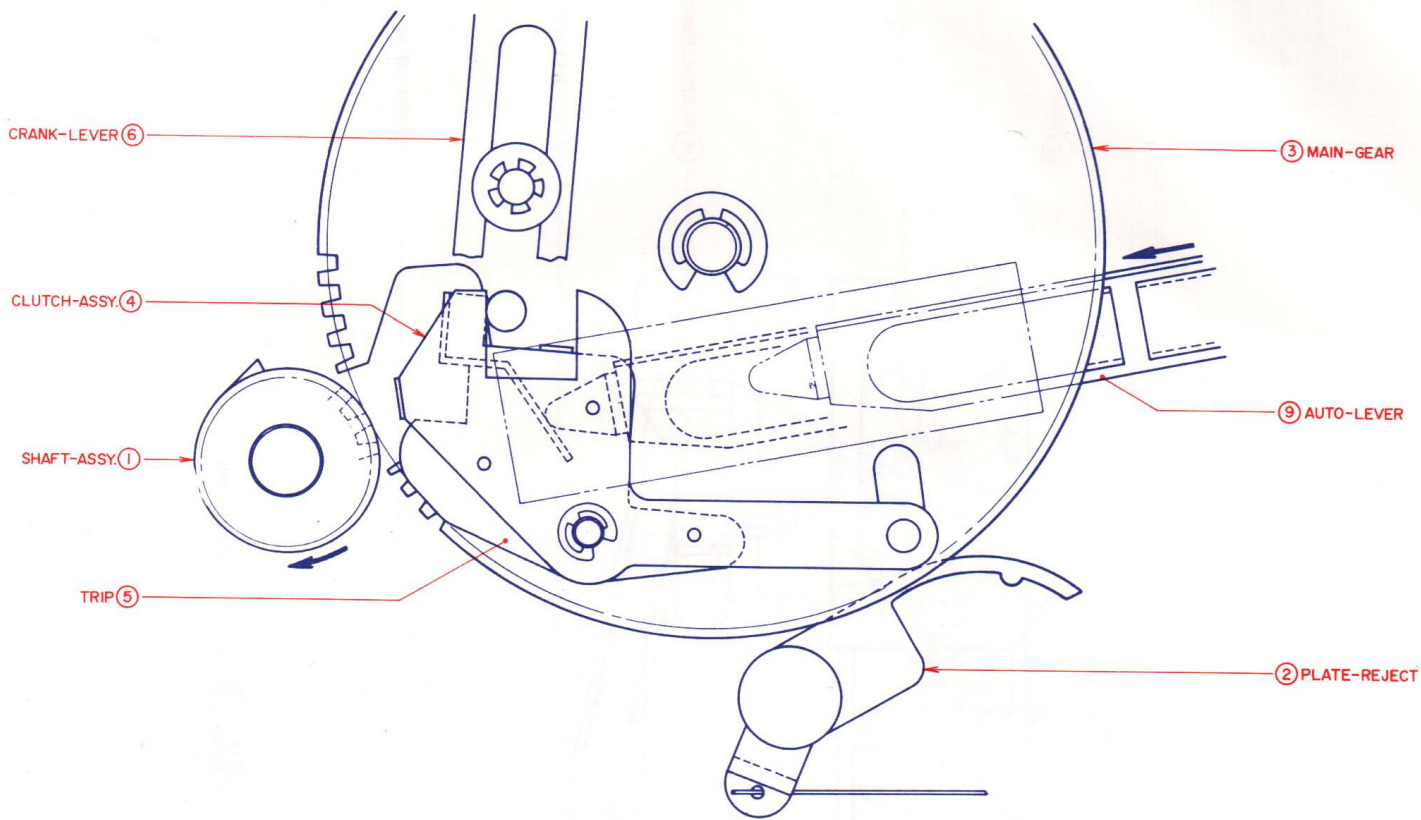

Fig. 4

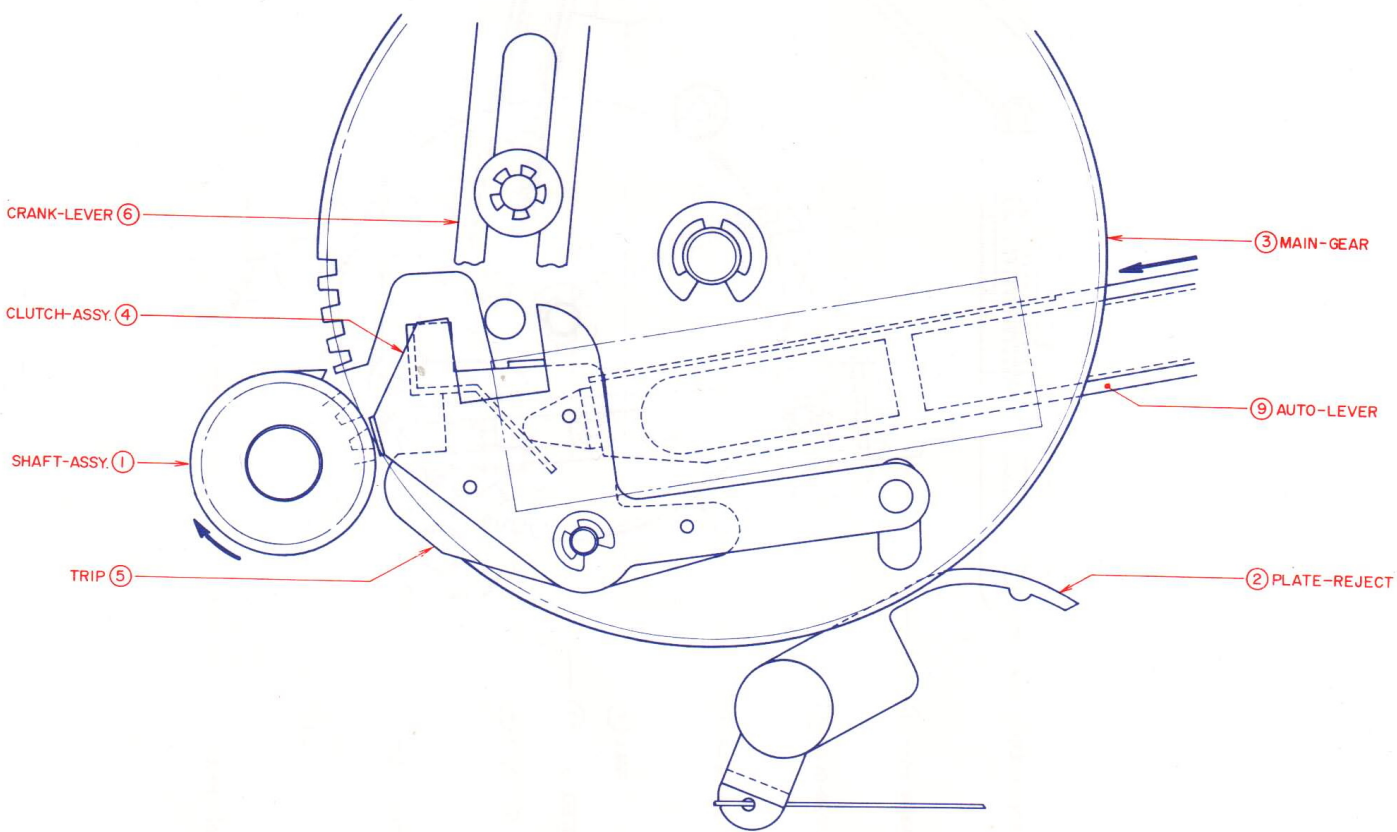

Fig. 5 PICK UP ARM STYLUS TIP IN VICINITY OF 126φ

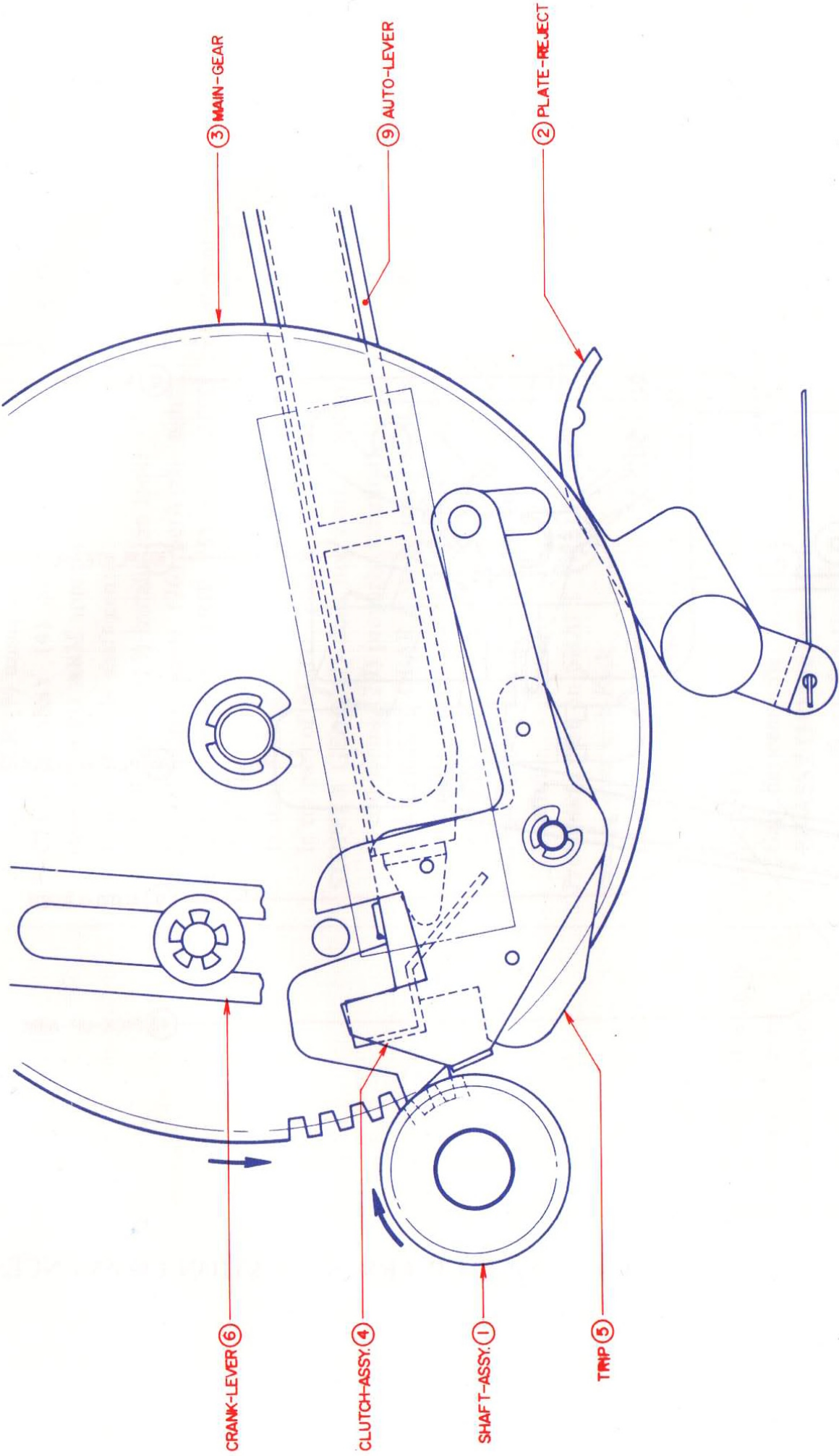

Fig. 6 MAIN-GEAR REVOLUTIONS BEGIN (AUTO RETURN BEGINS)

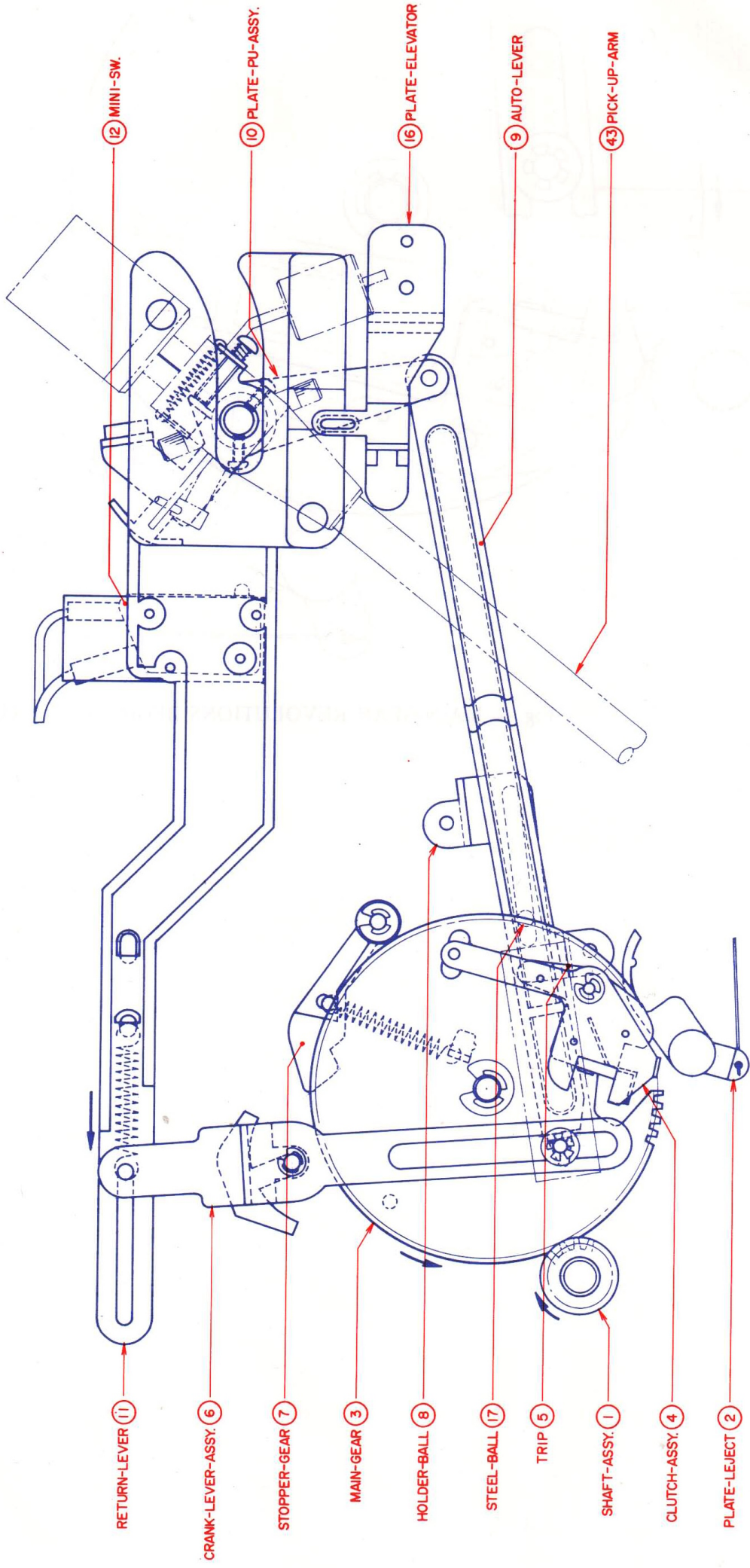

Fig. 7 PICK UP ARM ELEVATION COMMENCES

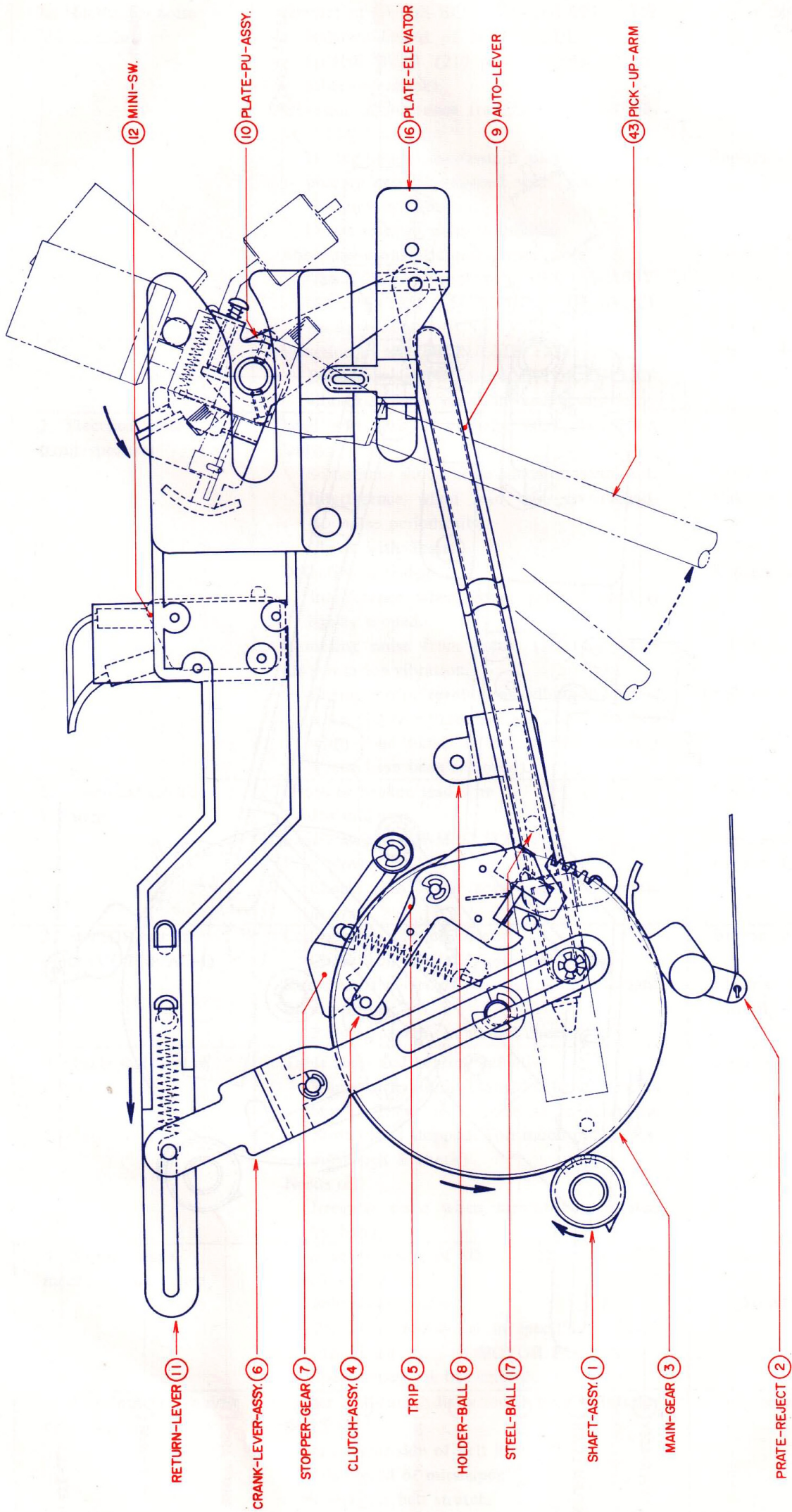

Fig. 8 PICK UP ARM RETURN COMMENCES

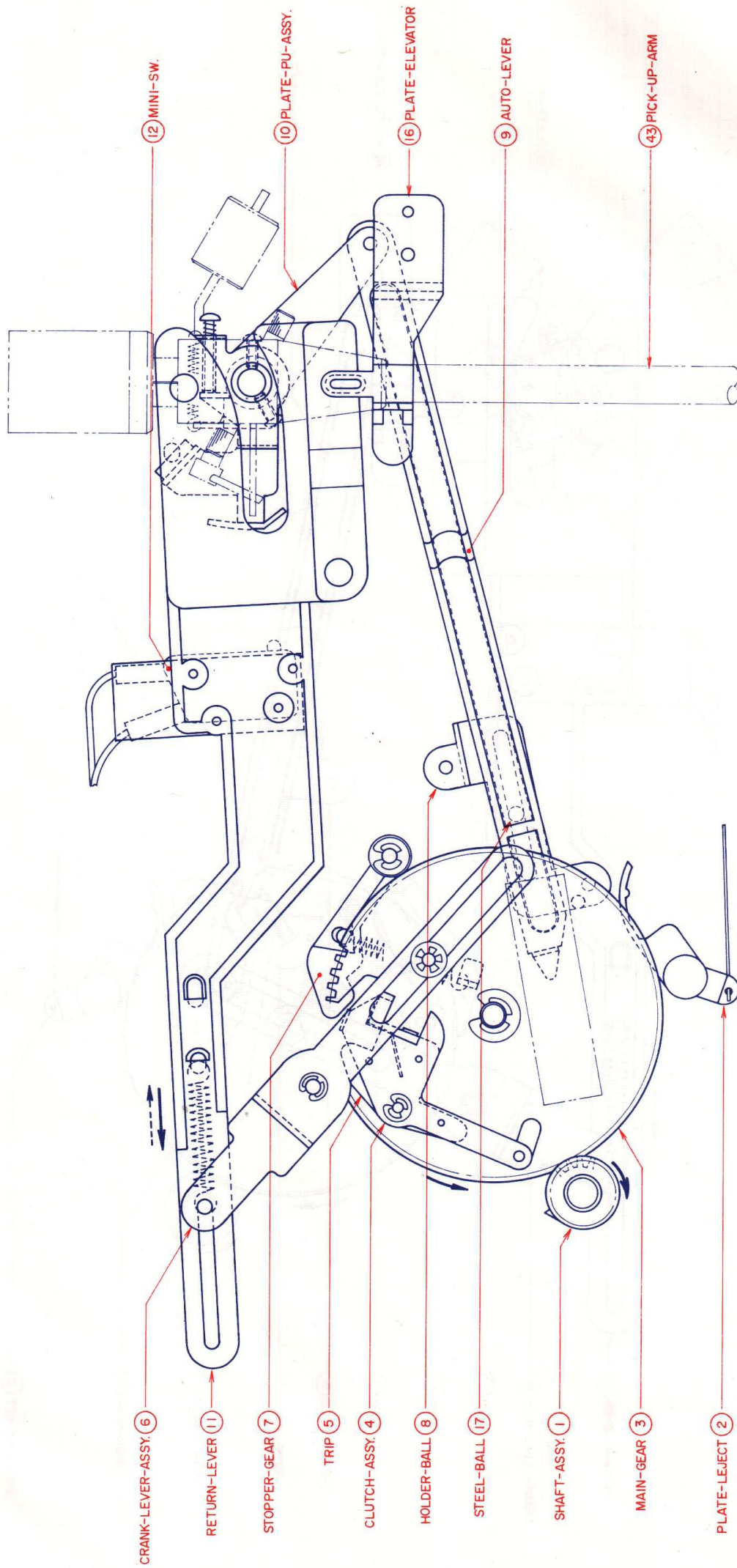

Fig. 9 PICK UP ARM ON REST TURNTABLE REVOLUTIONS CONTINUE

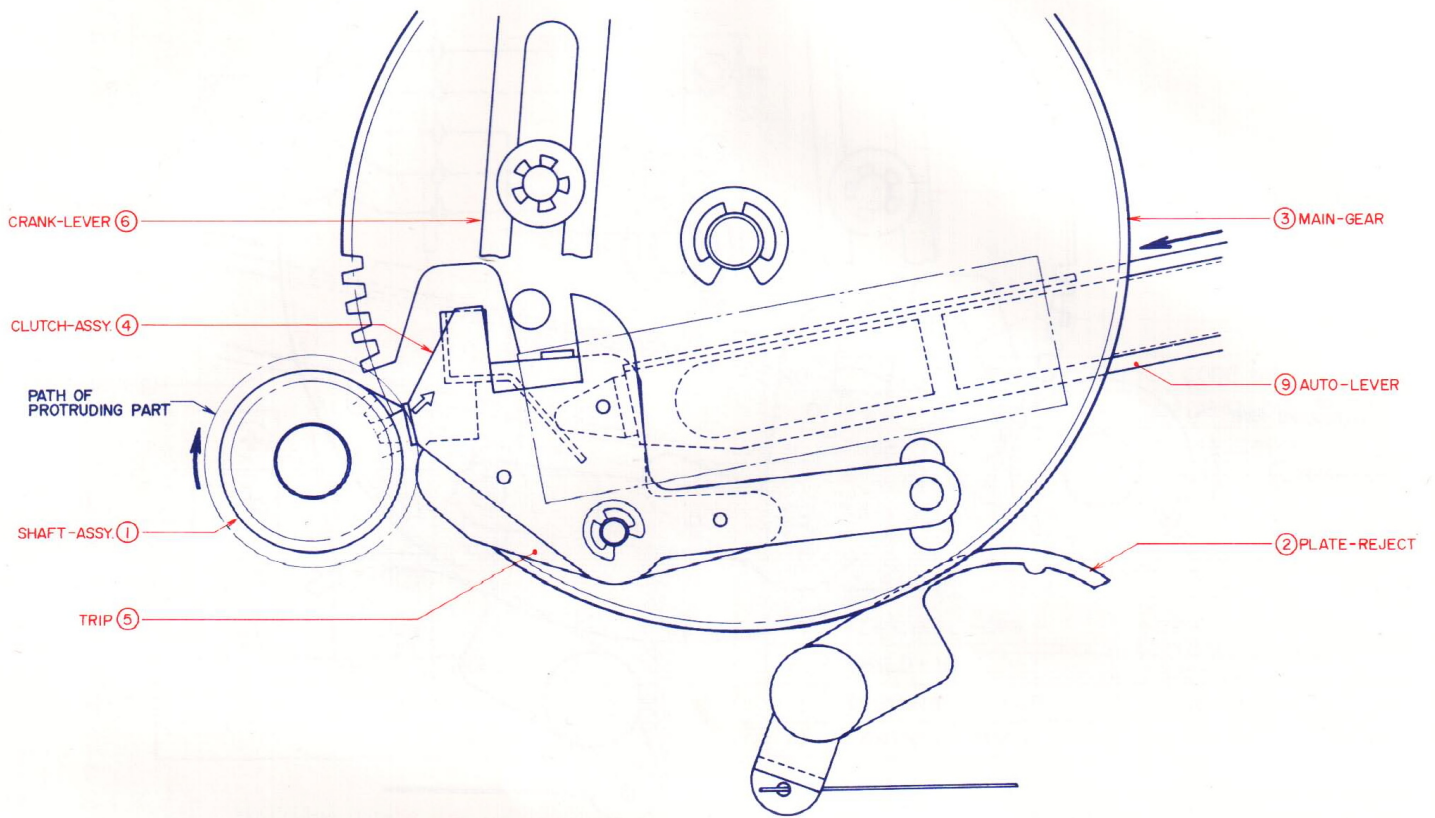

Fig. 10 NON RETURN CONDITION

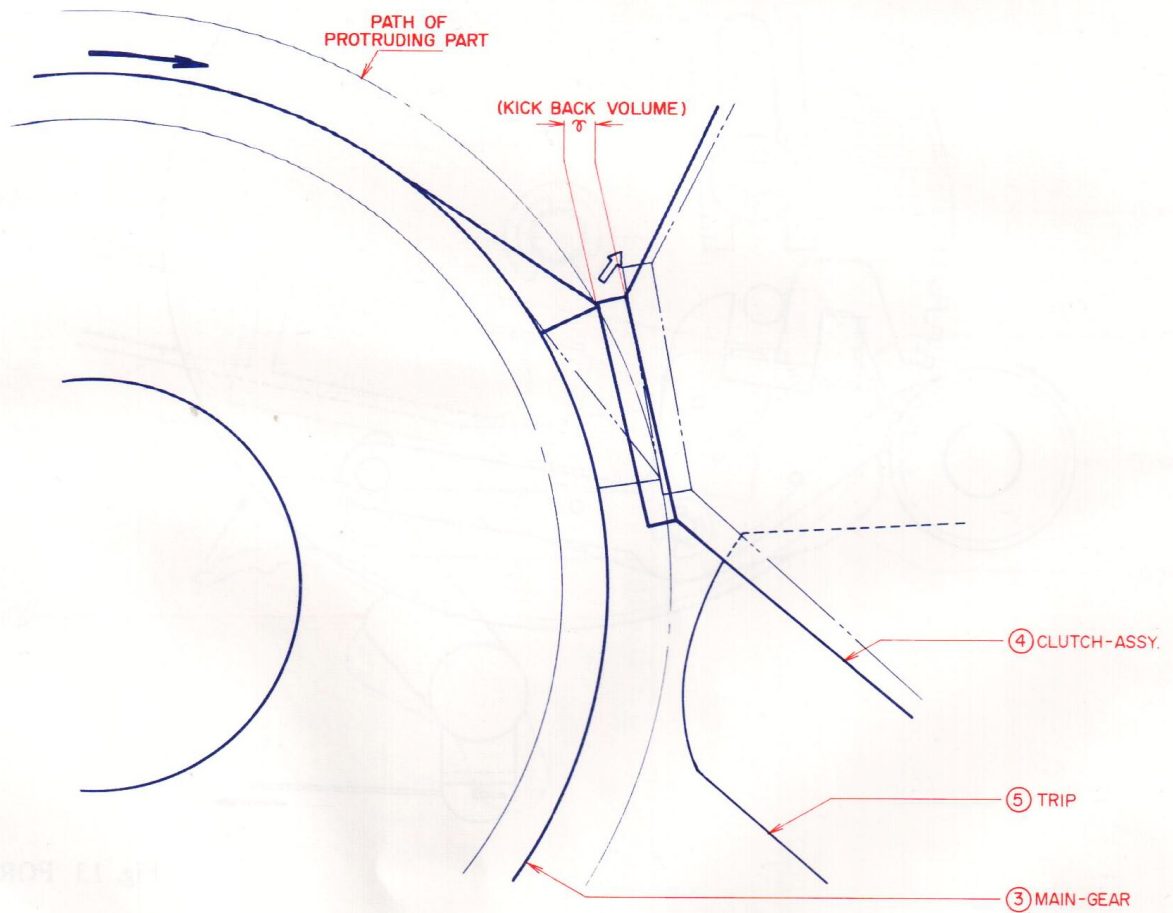
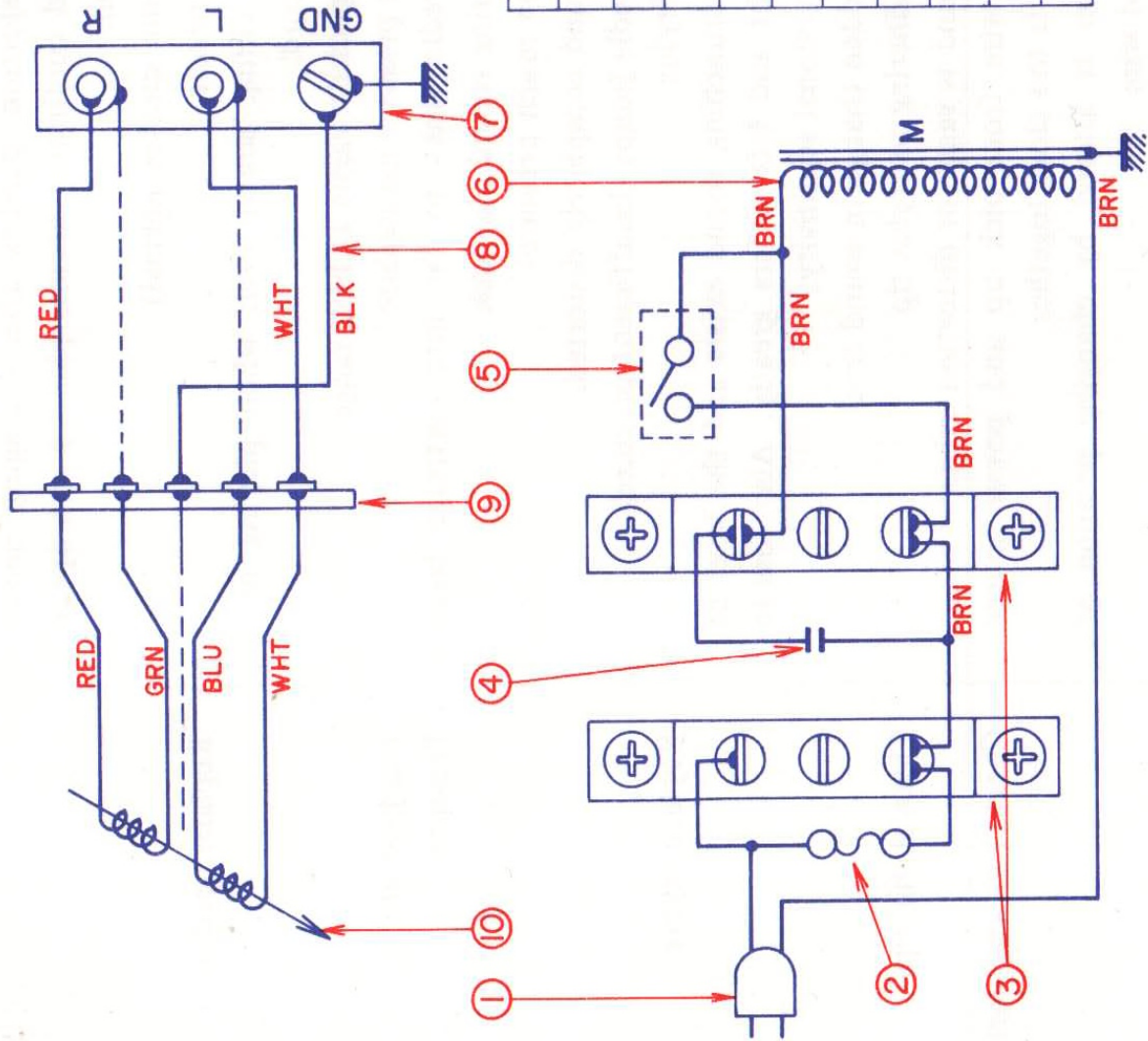

Fig. 11

3. Model AP-002D



NO.	DESCRIPTION	Q'ty	CODE NO.
1	CORD-PWR-JA	1	2217643600
2	FUSE-IJ	1	2214422400
3	TERMINAL-3P	2	2216130200
4	CMMO.047-M-1000D	1	2237013900
5	MINI-SW	1	2214585400
6	MOTOR-AC-4-D	1	2212540700
7	TERMINAL-CPX	1	2216204900
8	SHILD-IC	1	2217822000 2217821900
9	TERMINAL-IL-4P	1	2216105700
10	CARTRIGE-MM		

Fig. 19

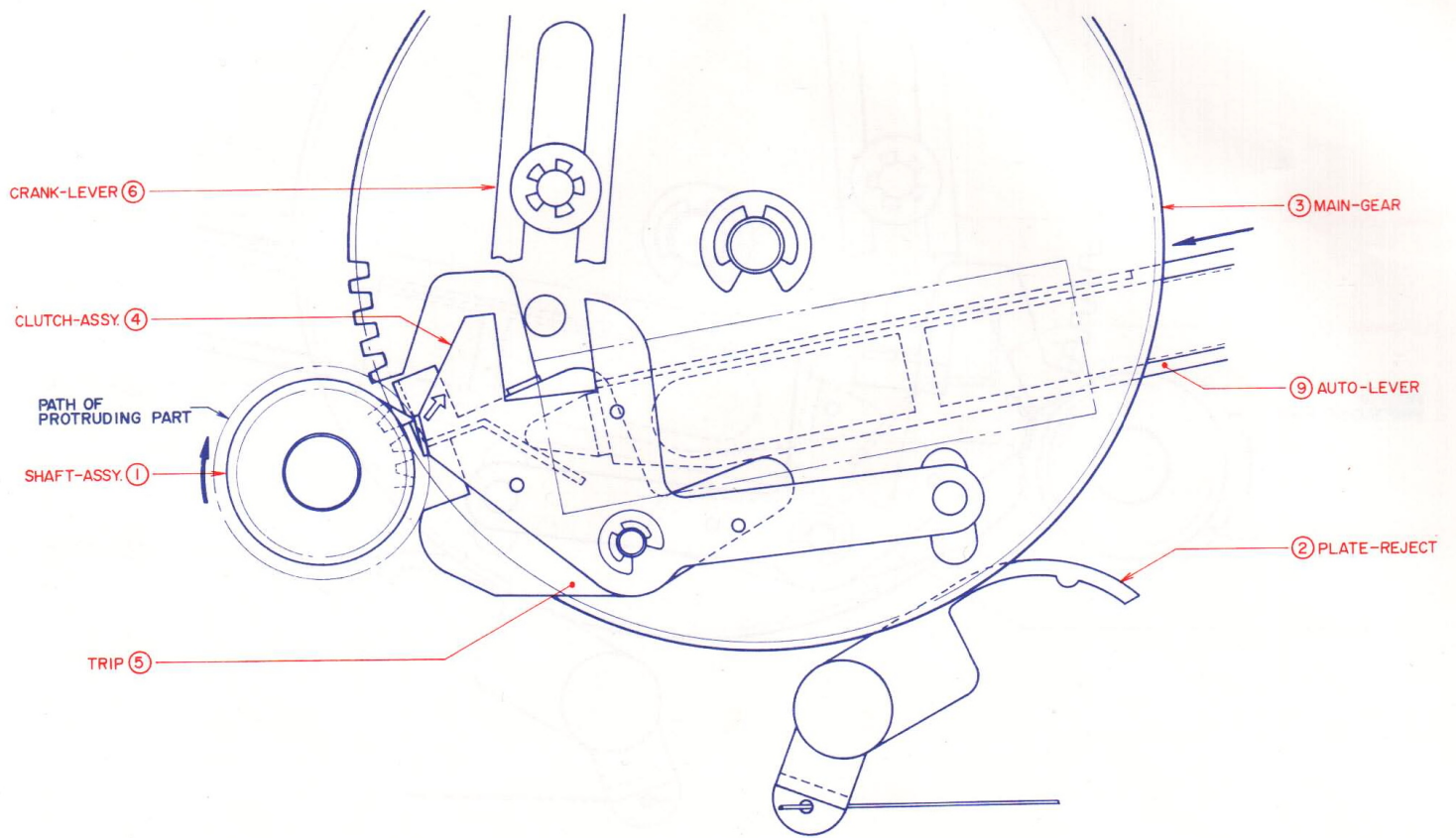

Fig. 12 NON RETURN CONDITION

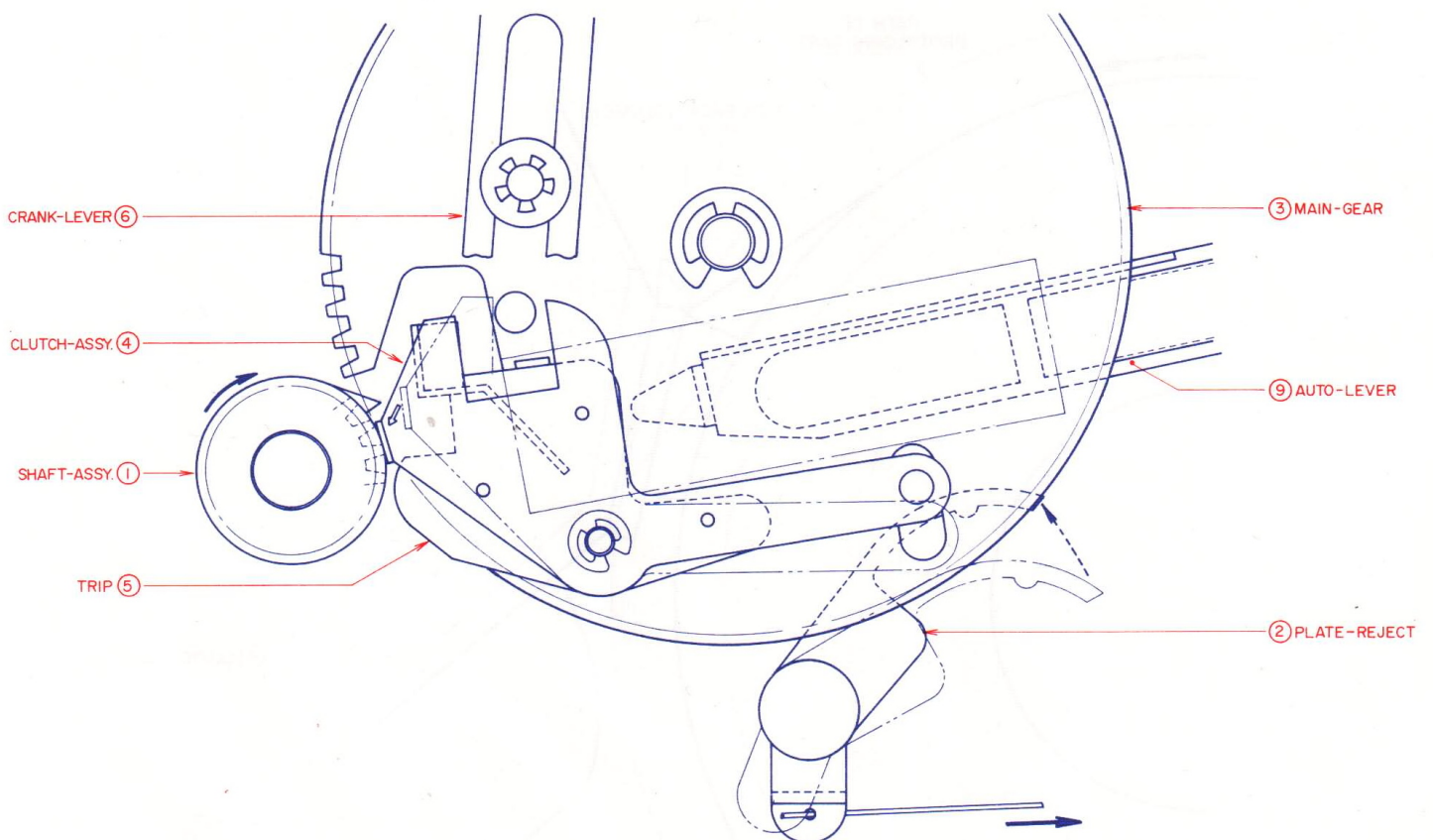

Fig. 13 FORCE CUT

IV. VARIOUS ADJUSTMENT

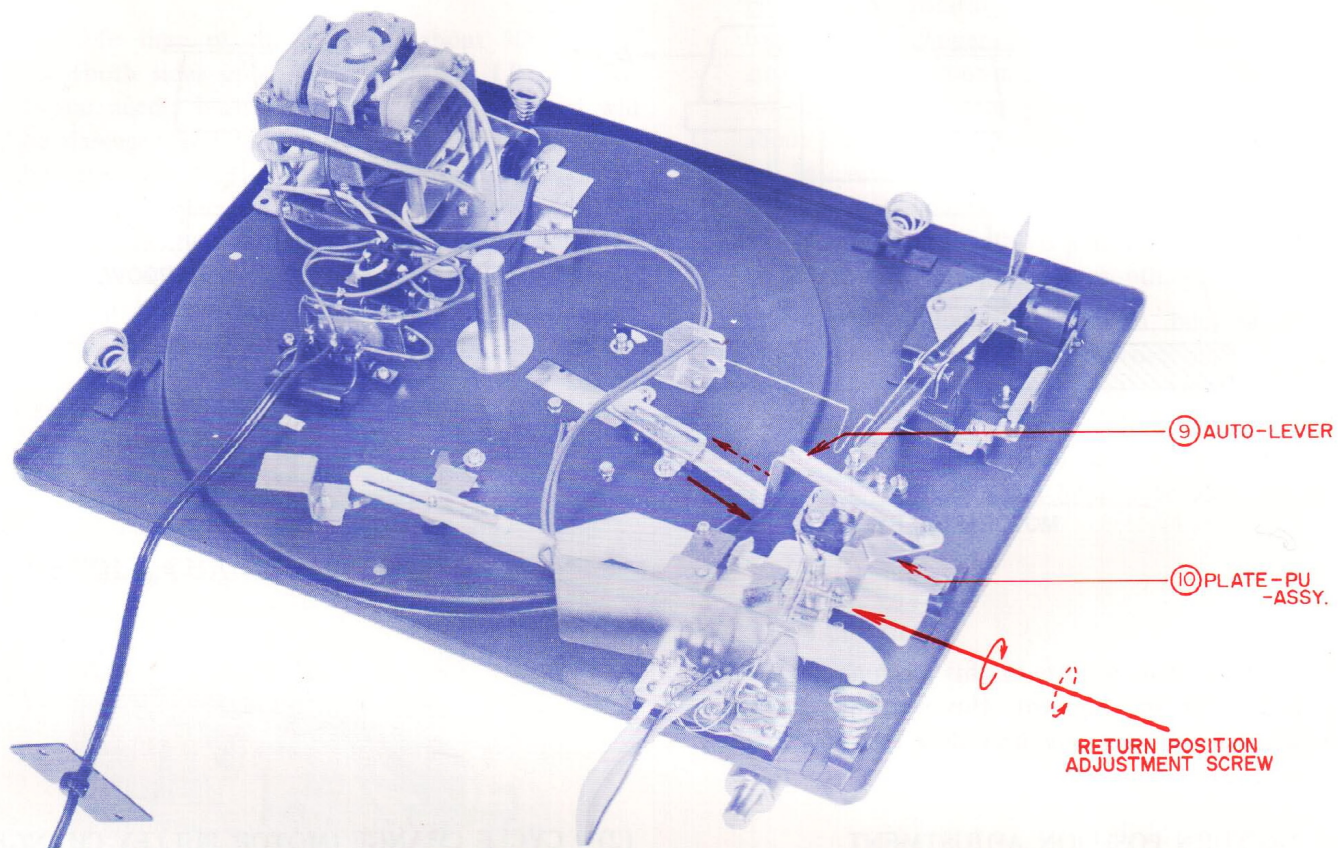

Fig. 14

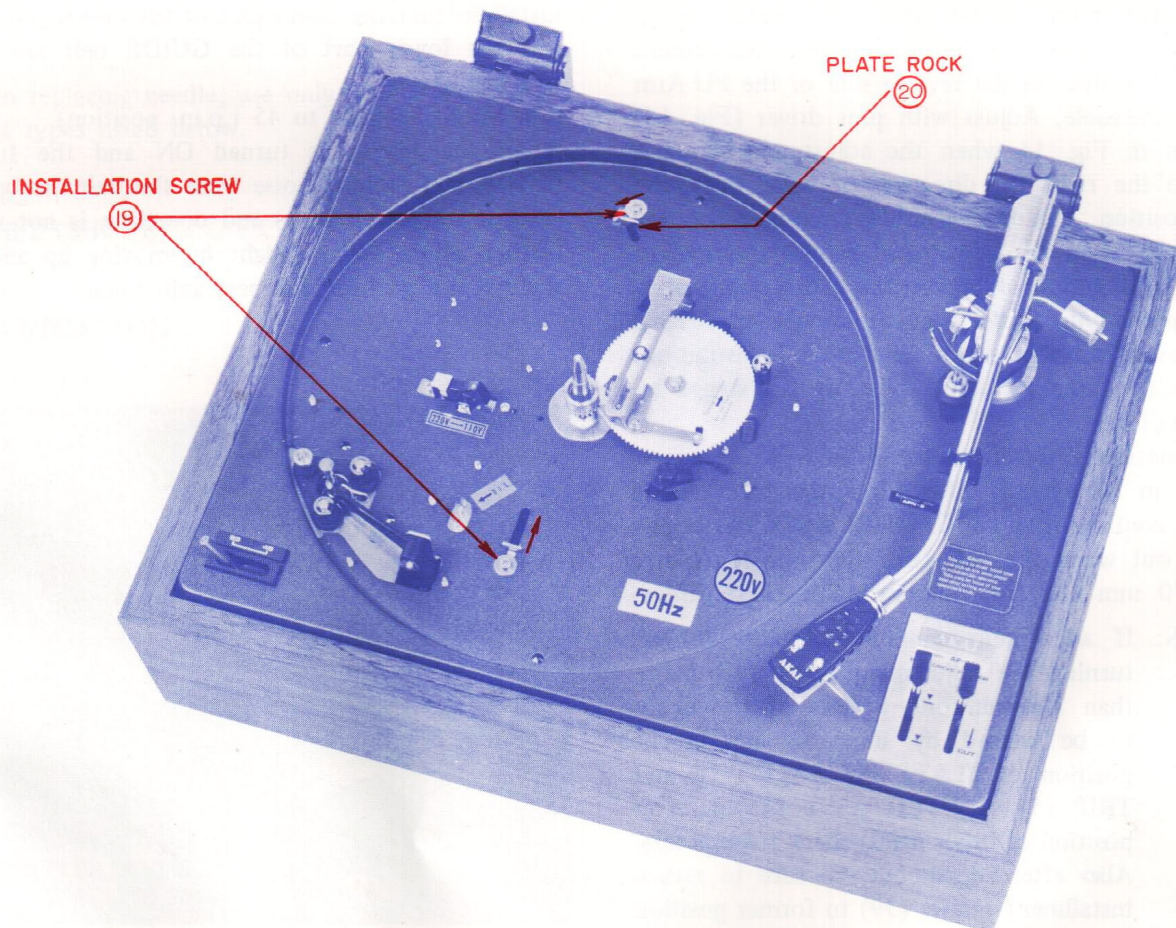
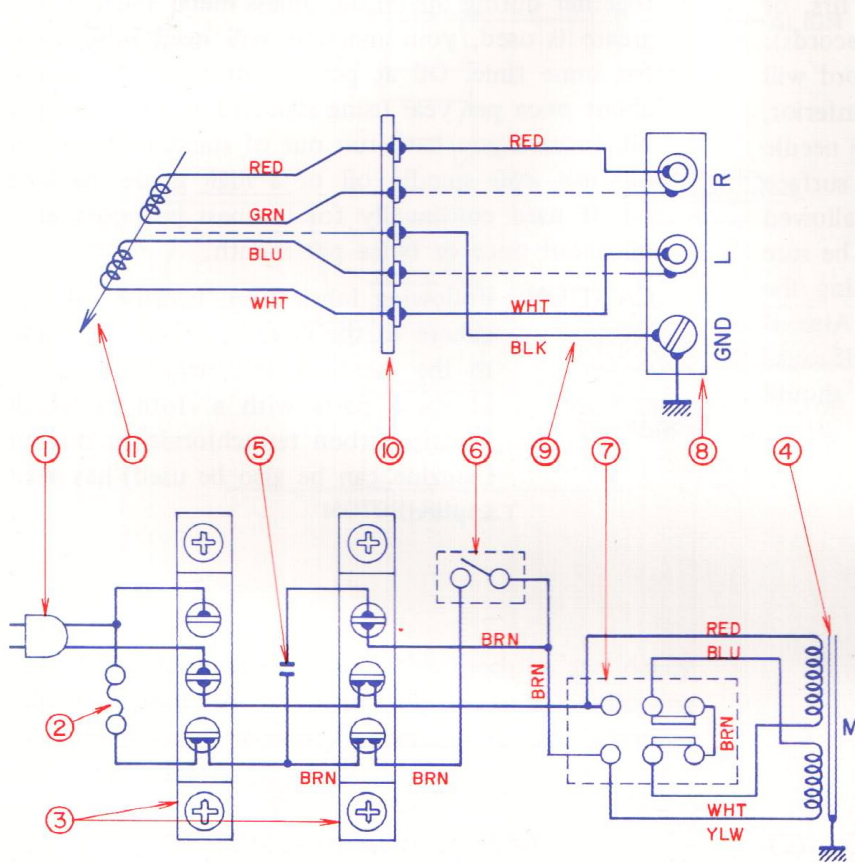

Fig. 15

VI. BLOCK DIAGRAM

1. Model AP-002 (A)



NOTE:
SWITCH INSTALLMENT DIRECTION

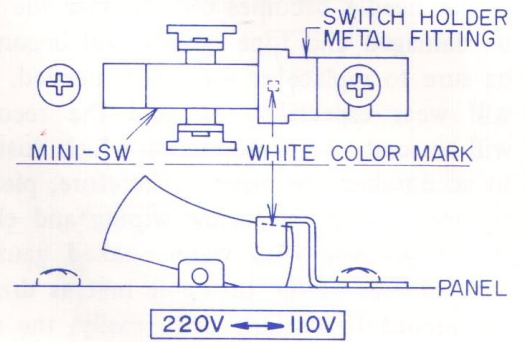

NO.	DESCRIPTION	Qty	CODE NO.
1	CORD-PWR-UC	1	2217619900
2	FUSE-IJ	1	2214422400
3	TERMINAL-3P	2	2216130200
4	MOTOR-AC-4-A	1	2212540400
5	CMMO.047-M-1000D	1	2237013900
6	MINI-SW	1	2214585400
7	SEESAW-SW	1	2214644700
8	TERMINAL-CPX	1	2216204900
9	SHILD-IC	1	2217822000 2217821900
10	TERMINAL-IL-4P	1	2216105700
11	CARTRIGE-MM	1	2215530000

Fig. 17

2. Model AP-002 (B)

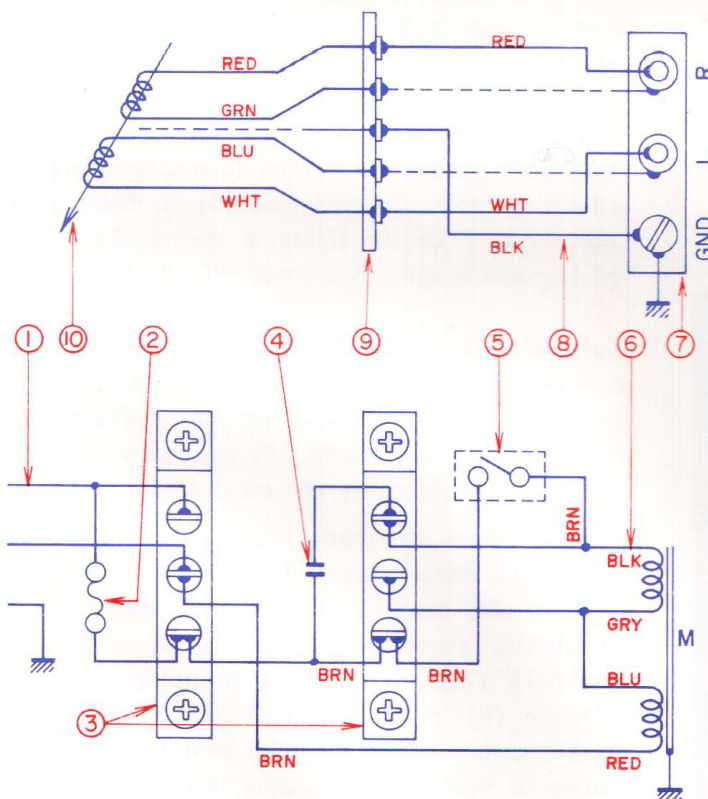

NO.	DESCRIPTION	Qty	CODE NO.
1	CORD-PWR-SA	1	2217705100
2	FUSE-IJ	1	2214422400
3	TERMINAL-3P	2	2216130200
4	CMMO.047-M-1000D	1	2237013900
5	MINI-SW	1	2214585400
6	MOTOR-AC-4-B	1	2212540500
7	TERMINAL-CPX	1	2216204900
8	SHILD-IC	1	2217822000 2217821900
9	TERMINAL-IL-4P	1	2216105700
10	CARTRIGE-MM	1	2215530000

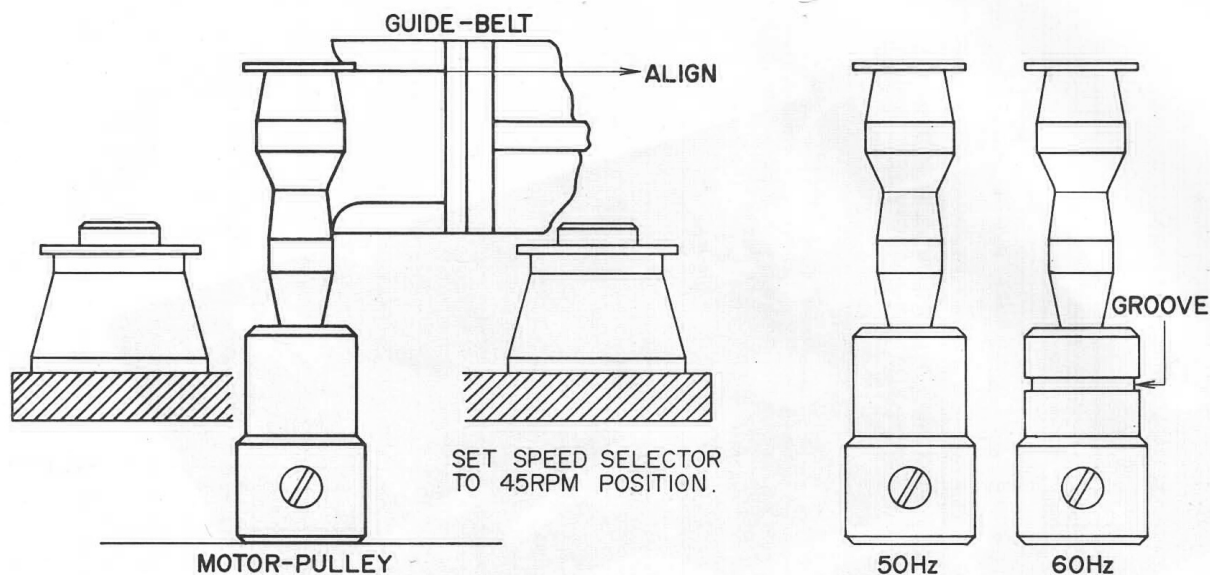

Fig. 16

All of the stationary parts of this machine are ideally adjusted prior to shipment. However, the following adjustments are necessary according to circumstances involving usage:

(1) RETURN POSITION ADJUSTMENT

Remove turntable and loosen the plate holder metal fitting (PLATE LOCK (20)). This can be accomplished after loosening the two installation screws (19) on the table mount 2 or 3 turns. (Fig. 15) Because this separates the table mount and the cabinet by a considerable degree, the return position adjustment screw (18) located on the reverse side of the PU Arm becomes accessible. Adjust with plus driver (Fig. 14) As shown in Fig. 14 when the adjustment screw is turned to the right (in direction of solid line), the return position is slowed (inside circumference approach) and when the adjustment screw is turned to the left (in direction of broken line), the return position is speeded up (outside circumference approach). (When the adjustment screw is turned 1 revolution, the position of the PU Arm stylus tip is changed by about 8 m/m).

Always confirm this adjustment with a JIS specification 30 cm LP record. Also while the turntable is removed, confirm that the CLUTCH ASSY (4) begins to move out when the PU Arm stylus tip is 64 mm (R) to 70 mm (R) from the turntable shaft center.

CAUTION: If adjustment cannot be made without turning the adjustment screw (18) more than 2 revolutions, because this is likely to be caused by improper installment position of PLATE PU ASSY (10) and TRIP (5), CLUTCH ASSY (4) etc. (by position of other parts) check these points. Also after adjustment, be sure to return installment screws (19) to former position and tighten.

(2) CYCLE CHANGE (MOTOR PULLEY CHANGE)

Cycle change is effected by changing the motor pulley. 50 and 60 Hz differentiation can be determined by the groove on the 60 Hz pulley. (See Fig. 16)

While viewing horizontally as shown in the figure, install so that the lower part of the motor pulley brim and the lower part of the GUIDE belt are aligned (Refer to figure).

(Set Speed Selector to 45 r.p.m. position).

When the player is turned ON and the turntable rotates, if a rubbing noise from the belt can be heard, (except while switching) and operation is not smooth, further adjust pulley height by moving up and down slightly and position for best adjustment.

V. PLAYER CARE

1. LIFE OF NEEDLE (STYLUS TIP)

The life time of the needle is about 500 hrs. of use (both sides of about 500 30 cm LP records). If the needle becomes old, because the record will be damaged and tone quality will become inferior, be sure to replace as soon as is needed. The needle will wear especially fast and the record surface will be scratched if records on which dust is allowed to accumulate are played. Therefore, please be sure to keep record clean by wiping and cleaning the record grooves with water soaked gauze. Also if dust adheres to the turntable mat as this will cause the record to become dirty easily, the mat should also be kept clean.

2. NEEDLE CHANGE

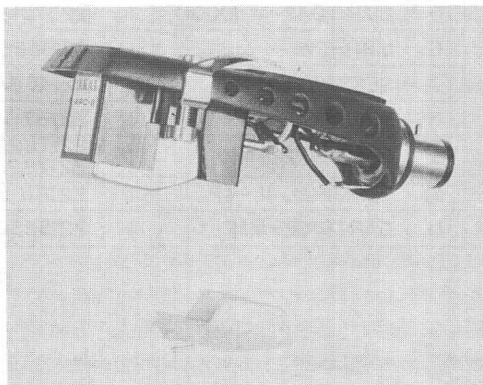

When replacing needle, use only one of the replacement types listed below.

APN-2
N75B/2 (SHURE)

3. LUBRICATION

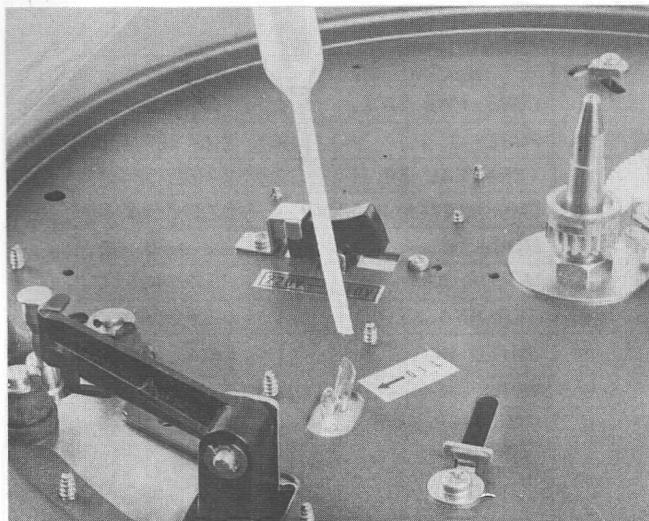

Because for rotating parts and parts which rub together during operation, oilless metal and the best grease is used, your machine will need lubrication for some time. Oil at points shown in illustration about once per year using standard accessory player oil. In case you have run out of standard accessory oil, use #60 spindle oil or a high grade machine oil. If used continually for business purposes, etc., oil about once or twice per month.

CAUTION: Following lubrication, because oil will adhere to the drive belt and pulley and to the turntable etc., wipe the oil off of these parts with a cloth to which a little carbon tetrachloride or thinner (benzine can be also be used) has been applied.