



AKAI DIRECT DRIVE TURNTABLE

MODEL **AP-007**

SECTION 1 SERVICE MANUAL 3

I. TECHNICAL DATA

TURNTABLE SECTION

TYPE	Direct Drive fully automatic turntable
PLATTER	325 mm diameter aluminum alloy die-cast (Weight: 1.15 kg)
SPEED	33-1/3 and 45 rpm
MOTOR	6 pole outer rotor AC servo controlled motor for turntable drive Geared motor for tone arm drive
WOW AND FLUTTER	0.03% WRMS (JIS C5521) $\pm 0.045\%$ Weighted zero to peak (DIN 45507)
SIGNAL TO NOISE RATIO	50 dB (DIN 45539A), 73 dB (DIN 45539B)
SPEED ADJUSTMENT RANGE	$\pm 4\%$ at 33-1/3 rpm, $\pm 5\%$ at 45 rpm

TONE ARM SECTION

TYPE	S-shaped static balanced type stainless steel tubular arm with inside force conceller and lateral balance weight
ARM LENGTH	220 mm
STYLUS PRESSURE ADJUSTMENT RANGE	0 to 3 grams
APPLICABLE CARTRIDGE WEIGHT	4.5 to 10.5 grams (8.5 to 14.5 grams using sub weight)
OFF-SET ANGLE	22°
TRACKING ERROR ANGLE	Within $\pm 2^\circ$
OVERHANG	15 mm
SHELL WEIGHT	9.5 grams
ARM LIFTER	Oil Damped type

MISCELLANEOUS

POWER REQUIREMENTS	CSA Models: 120V/60 Hz CEE and SEV Models: 220 V/50 Hz Other Models: 110 to 120 V/220 to 240 V, 50 to 60 Hz
DIMENSIONS	460(W) x 135(H) x 380(D) mm (18.1 x 5.3 x 14.9")
WEIGHT	9.5 kg (20.9 lbs)

* For improvement purposes, specifications and design are subject to change without notice.

3. PHOTO OF CABINET BLOCK



3) CABINET BLOCK

Ref. No.	Parts No.	Description	Schematic No.	Q'ty
3-1	BC740002	Cabinet Block Comp.		
		AP-007	2084781500	1
3-2	TP740005	Hinge (A) AP-007	2086169600	2
3-3x	ZS740006	Tapping Screw #2, 3x8 (Bind) (BLACK)		6
3-4	TP740007	Lamp Case AP-007	2272162200	1
3-5	SP740009	Bottom Cover AP-007	2084781600	1
3-6x	ZS740010	Tapping Screw #2, 4x12 (Pan)		12
3-7	BC740011	Dust Cover AP-007	2084781700	1
3-8	TP719897	Hinge (B)	2086168800	2
3-9	ZS538470	Screw, oval countersunk head 4x10		4
3-10x	TP740012	Cover (CSA, CEE) AP-007	2285469400	1

In case of trouble, etc. necessitating disassembly, please disassemble in the order shown in photographs. Reassemble in reverse order.

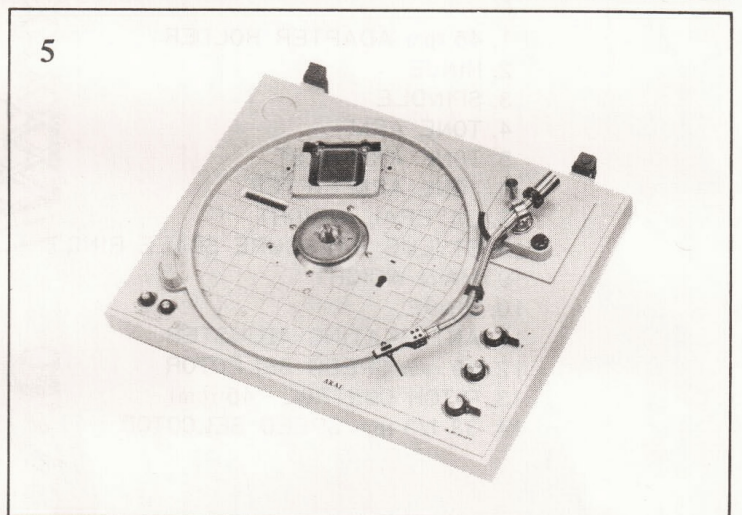
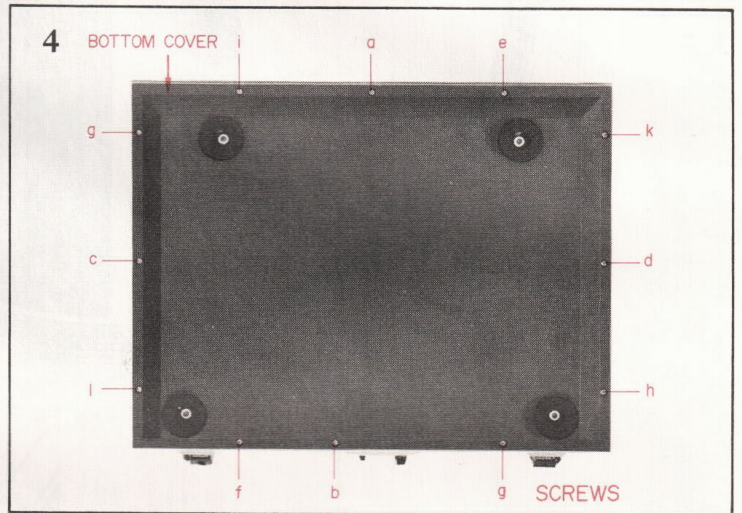

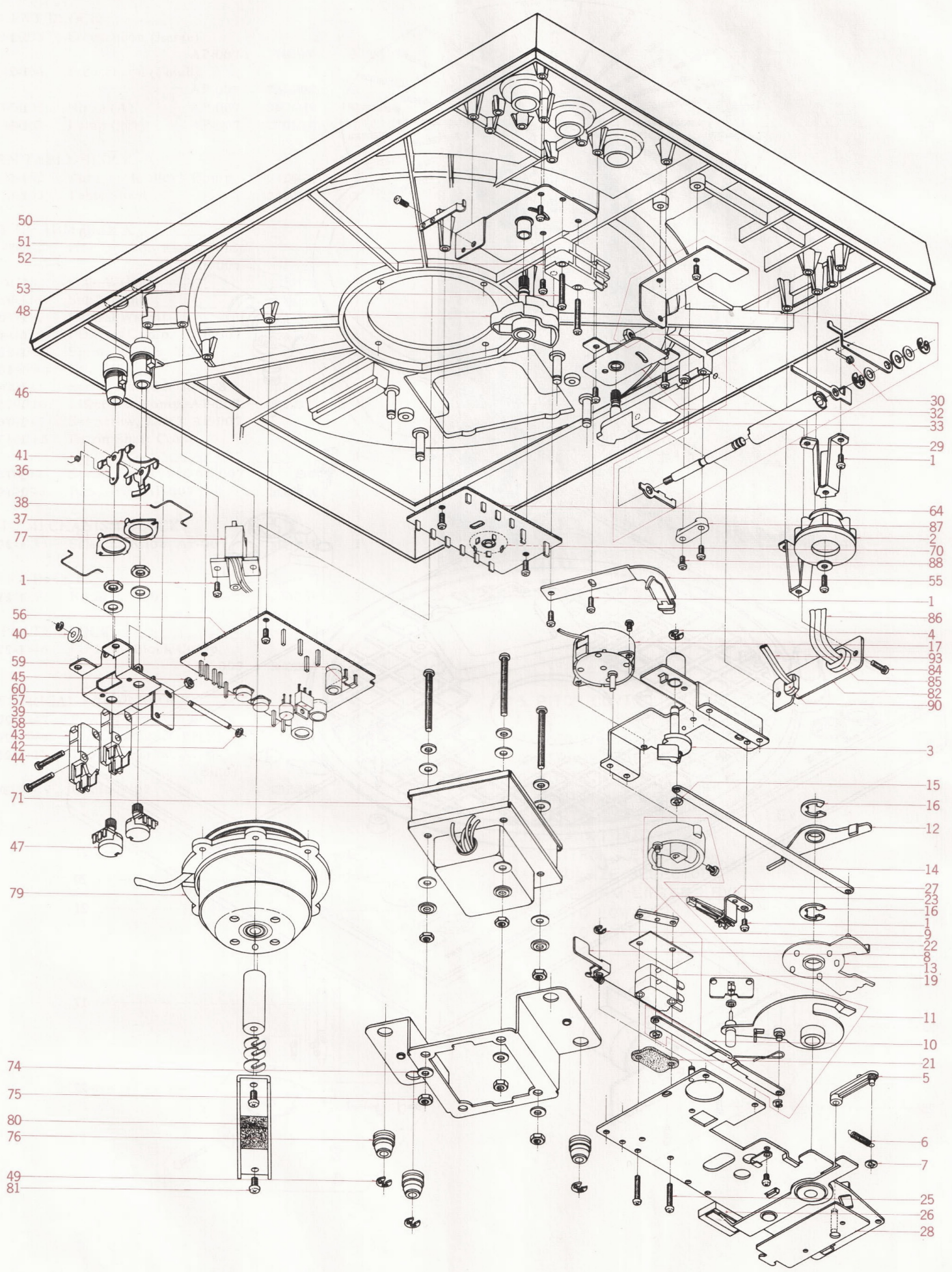

- 50
- 51
- 52
- 53
- 48
- 46
- 41
- 36
- 38
- 37
- 77
- 1
- 56
- 40
- 59
- 45
- 60
- 57
- 39
- 58
- 43
- 42
- 44
- 71
- 47
- 79
- 74
- 75
- 80
- 76
- 49
- 81

- 30
- 32
- 33
- 29
- 1
- 64
- 87
- 2
- 70
- 88
- 55
- 1
- 86
- 4
- 17
- 93
- 84
- 85
- 82
- 90
- 3
- 15
- 16
- 12
- 14
- 27
- 23
- 16
- 1
- 9
- 22
- 8
- 13
- 19
- 11
- 10
- 21
- 5
- 6
- 7
- 25
- 26
- 28

III. CONTROLS AND PRINCIPAL PARTS LOCATIONS

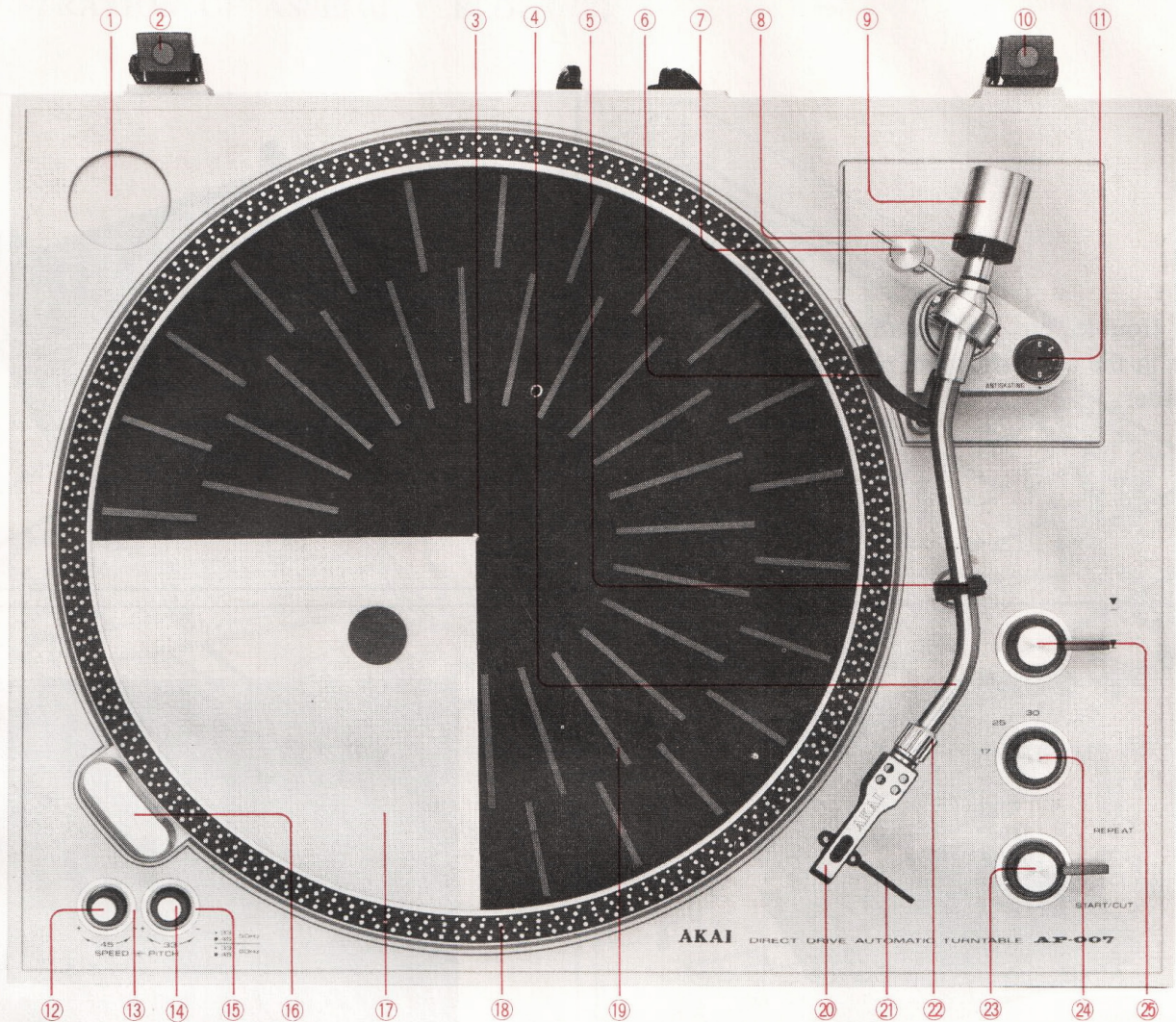
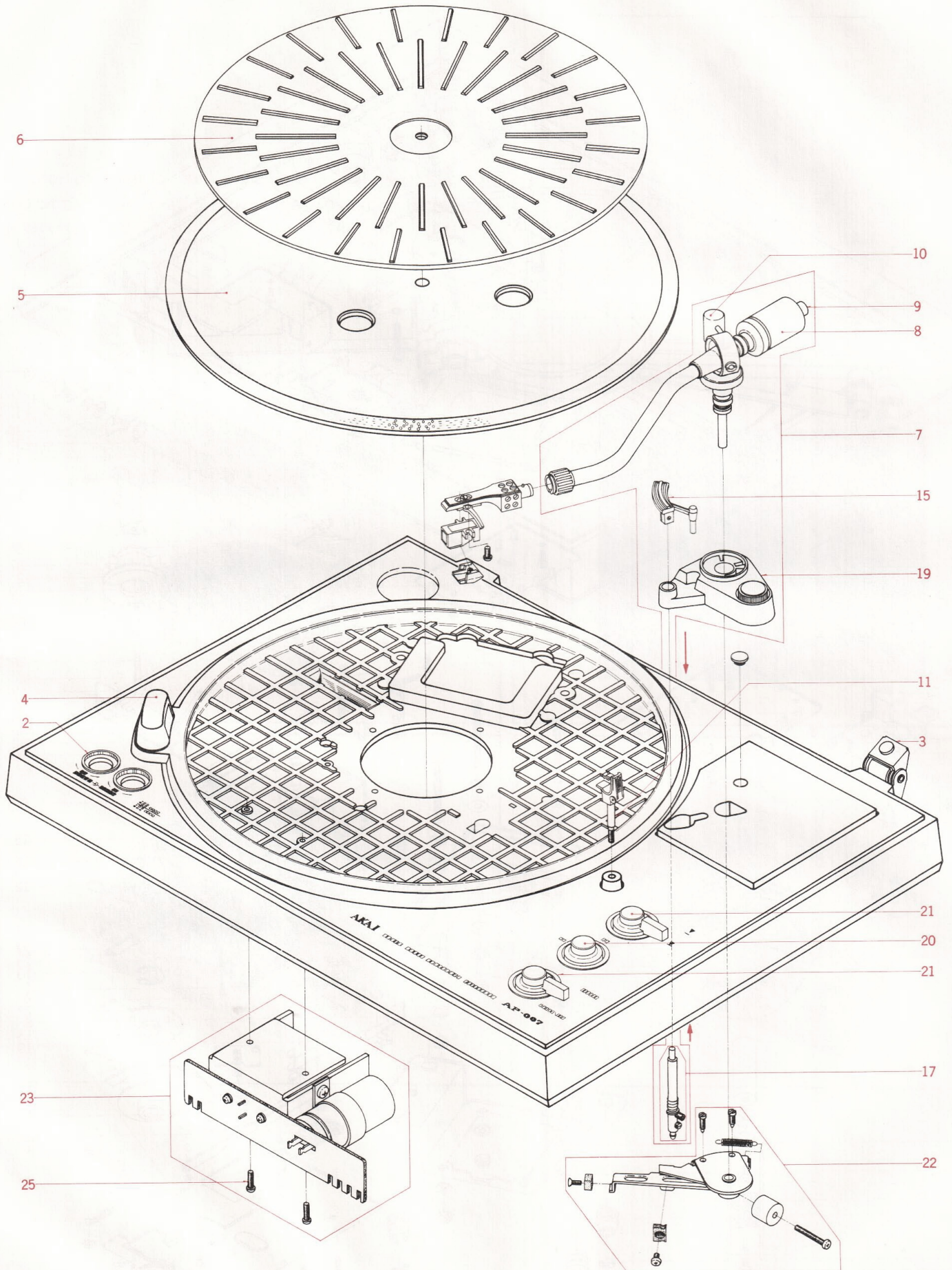

Fig. 1 Top View

- | | |
|-------------------------------|----------------------------------|
| 1. 45 rpm ADAPTER HOLDER | 15. PITCH CONTROL (33-1/3 rpm) |
| 2. HINGE | 16. BUILT-IN STROBE LIGHT |
| 3. SPINDLE | 17. TURNTABLE PLATTER |
| 4. TONE ARM | 18. STROBE MARKINGS |
| 5. TONE ARM REST | 19. RUBBER MAT |
| 6. TONE ARM LIFTER | 20. CARTRIDGE SHELL |
| 7. LATERAL WEIGHT | 21. CARTRIDGE SHELL FINGER LEVER |
| 8. STYLUS PRESSURE SCALE RING | 22. LOCKING NUT |
| 9. MAIN WEIGHT | 23. CONTROL LEVER |
| 10. HINGE | 24. DISC SIZE SELECTOR |
| 11. ANTI-SKATING ADJUSTER | 25. TONE ARM LIFTER LEVER |
| 12. 45 rpm SPEED SELECTOR | ▼ TO LOWER |
| 13. PITCH CONTROL (45 rpm) | ▼ TO LIFT |
| 14. 33-1/3 rpm SPEED SELECTOR | |

1. ILLUSTRATION OF ASSEMBLY BLOCK (1)



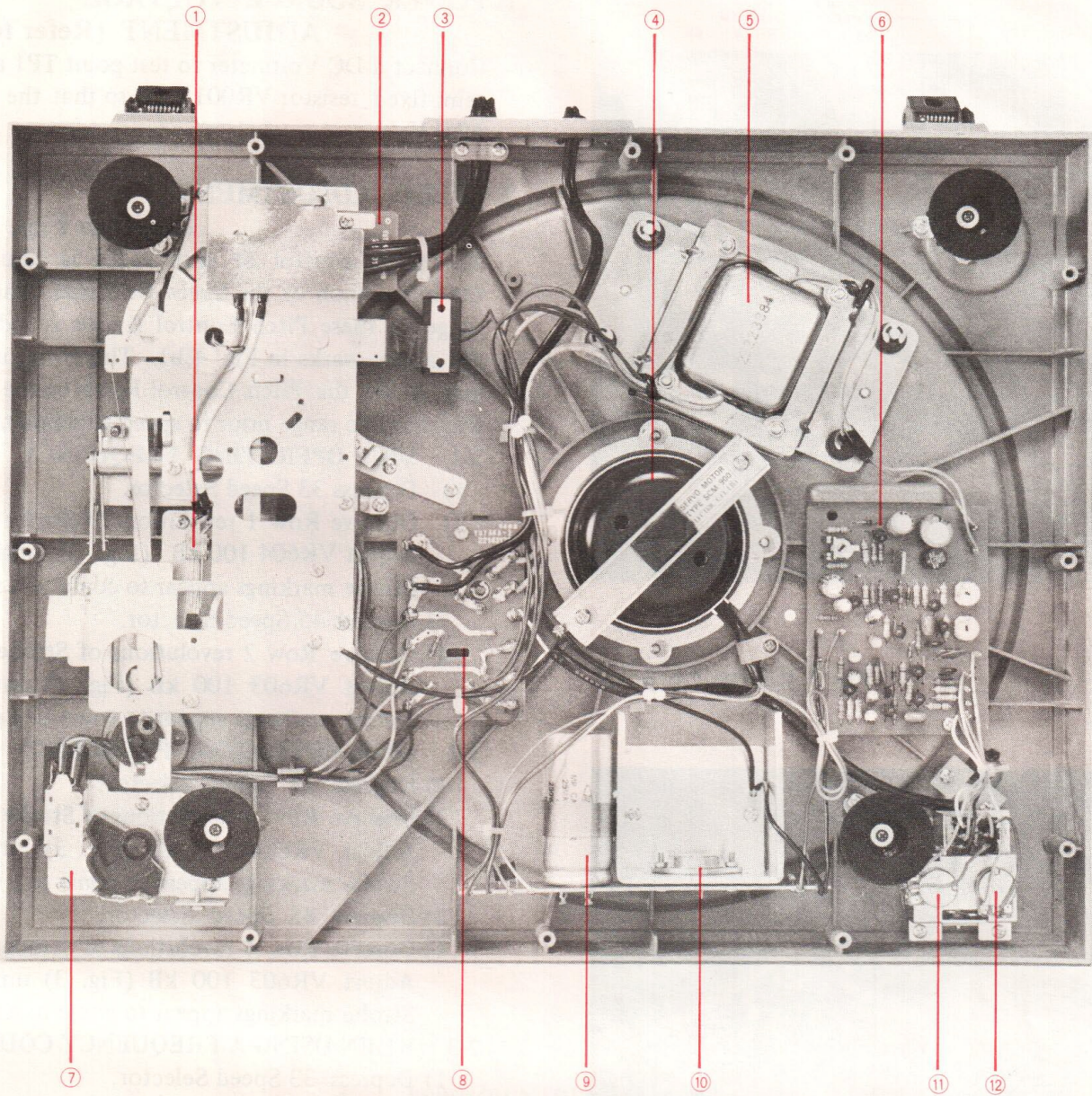

Fig. 2 Bottom View

1. MUTE SWITCH
2. PHONO P.C BOARD
3. REED SWITCH
4. AC SERVO MOTOR
5. POWER TRANSFORMER
6. CONTROL P.C BOARD
7. START/CUT, REPEAT SWITCH
8. SUPPLY P.C BOARD
9. PHASE CAPACITOR C614 4 μ /250V
10. POWER TRANSISTOR TR610 2SD198
11. 33-1/3 rpm SPEED/PITCH CONTROL
12. 45 rpm SPEED/PITCH CONTROL

IV. ADJUSTMENTS

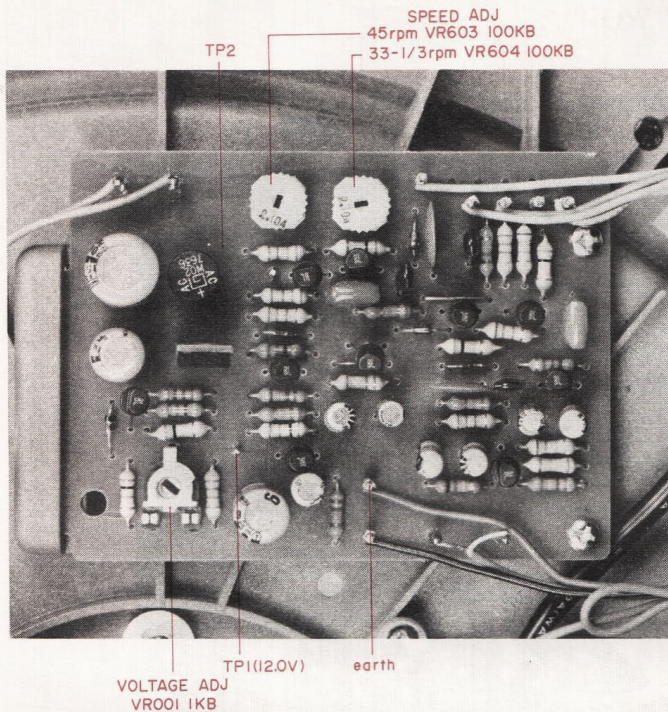

Fig. 3 Control P.C Board

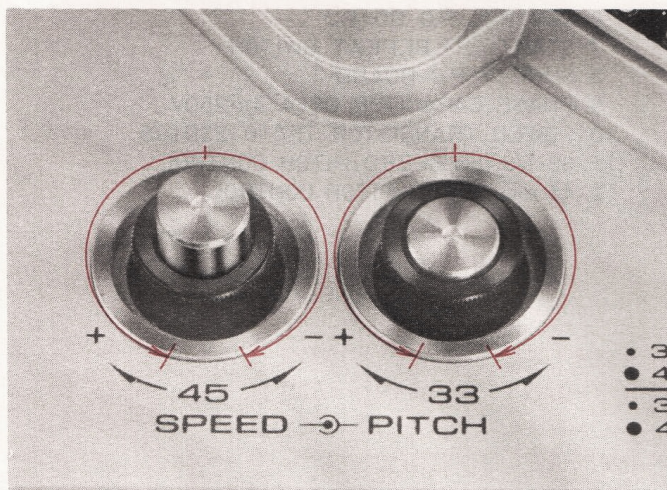
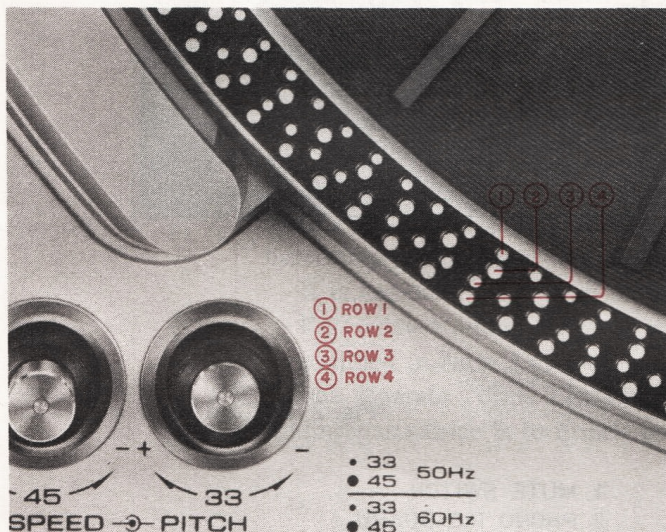

Fig. 4 Speed Adjustment

1. POWER SOURCE VOLTAGE

ADJUSTMENT (Refer to Fig. 3)

Connect a DC Voltmeter to test point TP1 and adjust semi-fixed resistor VR001 1 k Ω so that the voltage is 12.0 V.

2. SPEED ADJUSTMENT

(Refer to Figs. 3 and 4)

The pitch control of each speed is adjusted with the outer knob of the Speed Selectors. The movable range of these Pitch Control Knobs is indicated by the arrow marks in Fig. 4(b). Therefore, it is necessary to set the Pitch Control Knob to the center of this movable range prior to speed adjustment.

2-1 50Hz OPERATING FREQUENCY

- 1) Depress 33 Speed Selector.
- 2) Observe Row 1 revolutions of Strobe markings. Adjust VR604 100 k Ω (Fig. 3) until Row 1 Strobe markings appear to come to a stand-still.
- 3) Depress 45 Speed Selector.
- 4) Observe Row 2 revolutions of Strobe markings. Adjust VR603 100 k Ω (Fig. 3) until Row 2 Strobe markings appear to come to a stand-still.

2-2 60 Hz OPERATING FREQUENCY

- 1) Depress 33 Speed Selector.
- 2) Observe Row 3 revolutions of Strobe markings. Adjust VR604 100 k Ω (Fig. 3) until Row 3 Strobe markings appear to come to a stand-still.
- 3) Depress 45 Speed Selector.
- 4) Observe Row 4 revolutions of Strobe markings. Adjust VR603 100 k Ω (Fig. 3) until Row 4 Strobe markings appear to come to a stand-still.

2-3 WHEN USING A FREQUENCY COUNTER

- 1) Depress 33 Speed Selector.
- 2) Connect frequency counter to TP-2 and earth (Fig. 3). Adjust semi-fixed resistor VR604 100 k Ω for the frequency counter to read 83.333 Hz.
- 3) Depress 45 Speed Selector.
- 4) Connect frequency counter as in 2) and adjust semi-fixed resistor VR603 100 k Ω (Fig. 3) for the frequency counter to read 112.5 Hz.

* Perfect speed adjustment is attained when respective Strobe markings appear not to move.

* Once pre-set adjustment have been made, further readjustment is not necessary unless a Pitch Control is in some way moved. In this case, re-adjust.

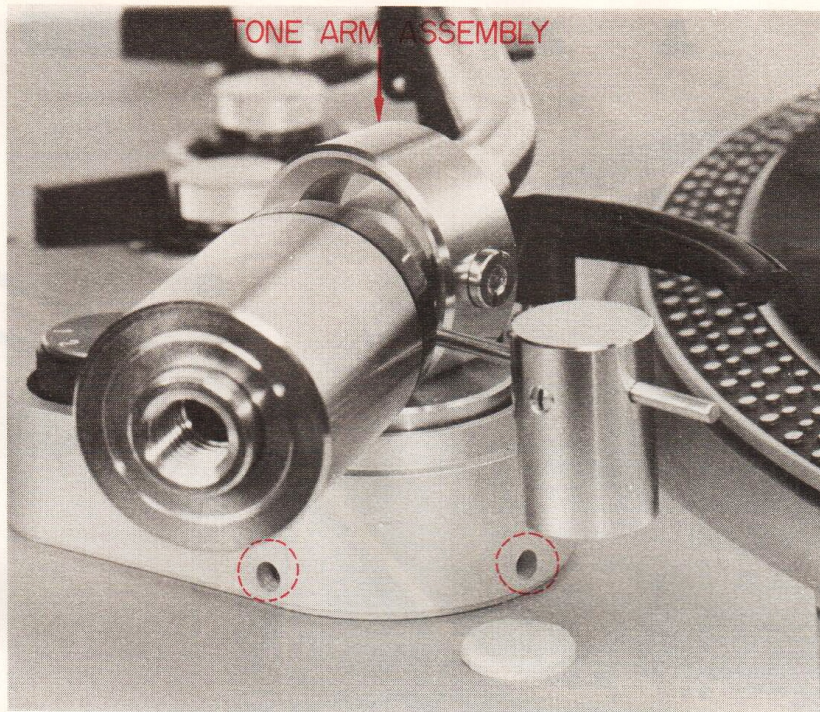

Fig. 5

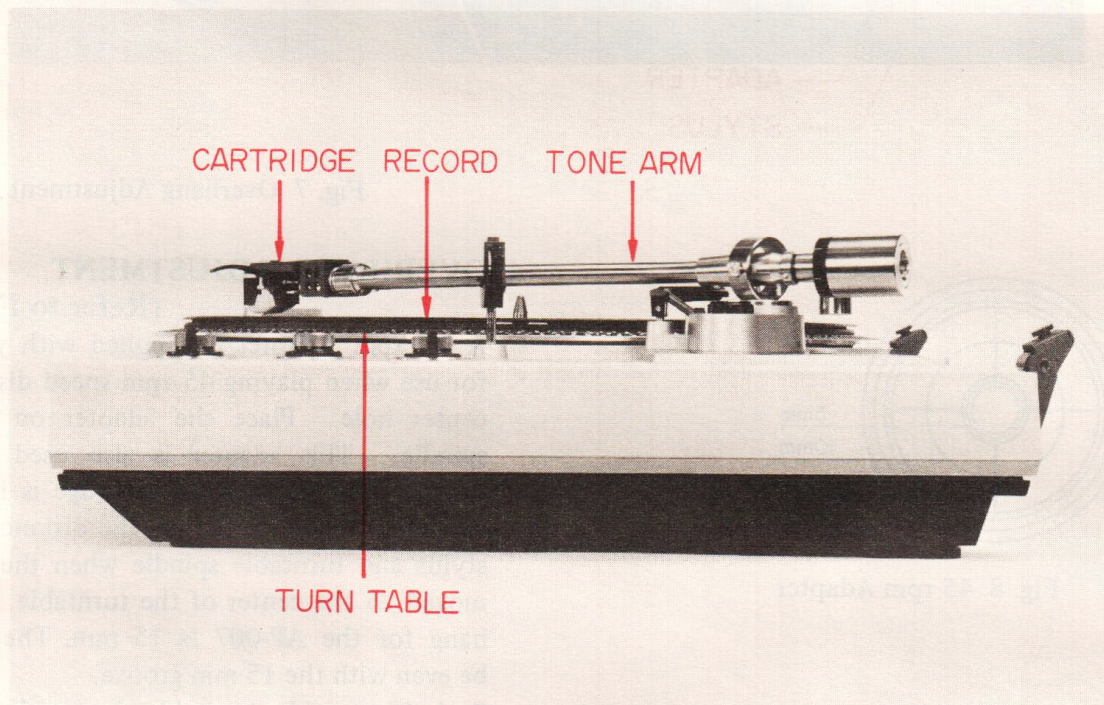

Fig. 6

3. TONE ARM HEIGHT ADJUSTMENT

(Refer to Figs. 5 and 6)

Tone Arm Height is factory adjusted to 17.3 mm to accommodate Model APC-5 cartridge. This can be adjusted by +5, -3 mm according to the height of the cartridge being used. If Tone Arm Height Adjustment is necessary, this can be accomplished as follows:

- 1) Use a minus driver as shown in Fig. 5 and loosen the two screws at the base of the tone arm assembly.
- 2) While playing a record, adjust tone arm height so that the tone arm is exactly horizontal as shown in Fig. 6 and tighten screw.

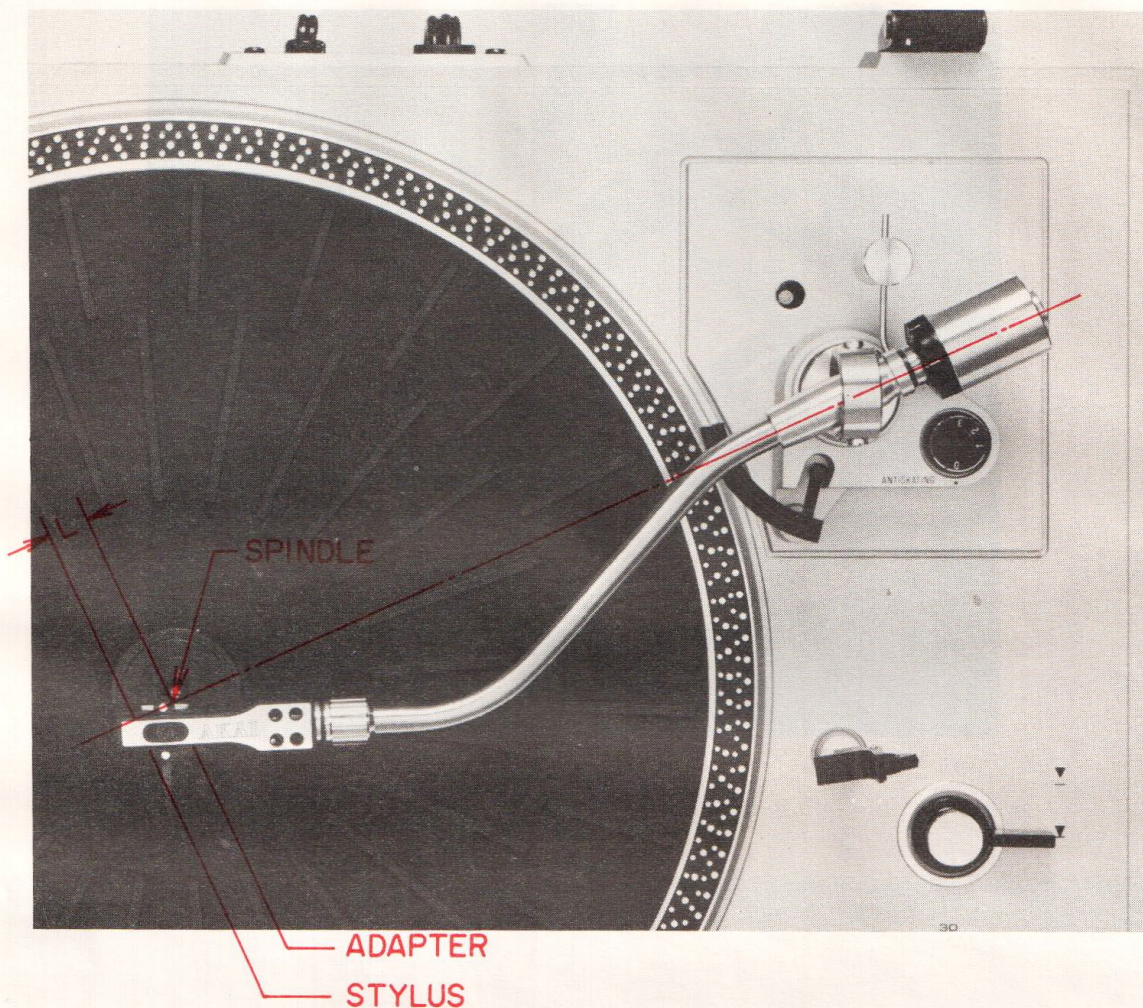

Fig. 7 Overhang Adjustment

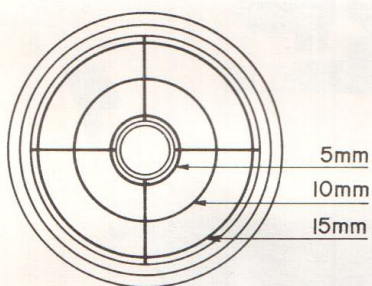

Fig. 8 45 rpm Adapter

4. OVERHANG ADJUSTMENT

(Refer to Figs. 7 and 8)

A 45 rpm Adapter is supplied with your turntable for use when playing 45 rpm speed discs with a large center hole. Place the adapter on the turntable spindle. This adapter is also used for obtaining proper overhang when a cartridge is installed. The overhang is determined by the distance between the stylus and turntable spindle when the Tone Arm is moved to the center of the turntable. Correct overhang for the AP-007 is 15 mm. The stylus should be even with the 15 mm groove.

* A 45 rpm adapter holder is provided on the upper left hand corner of the turntable for your convenience.

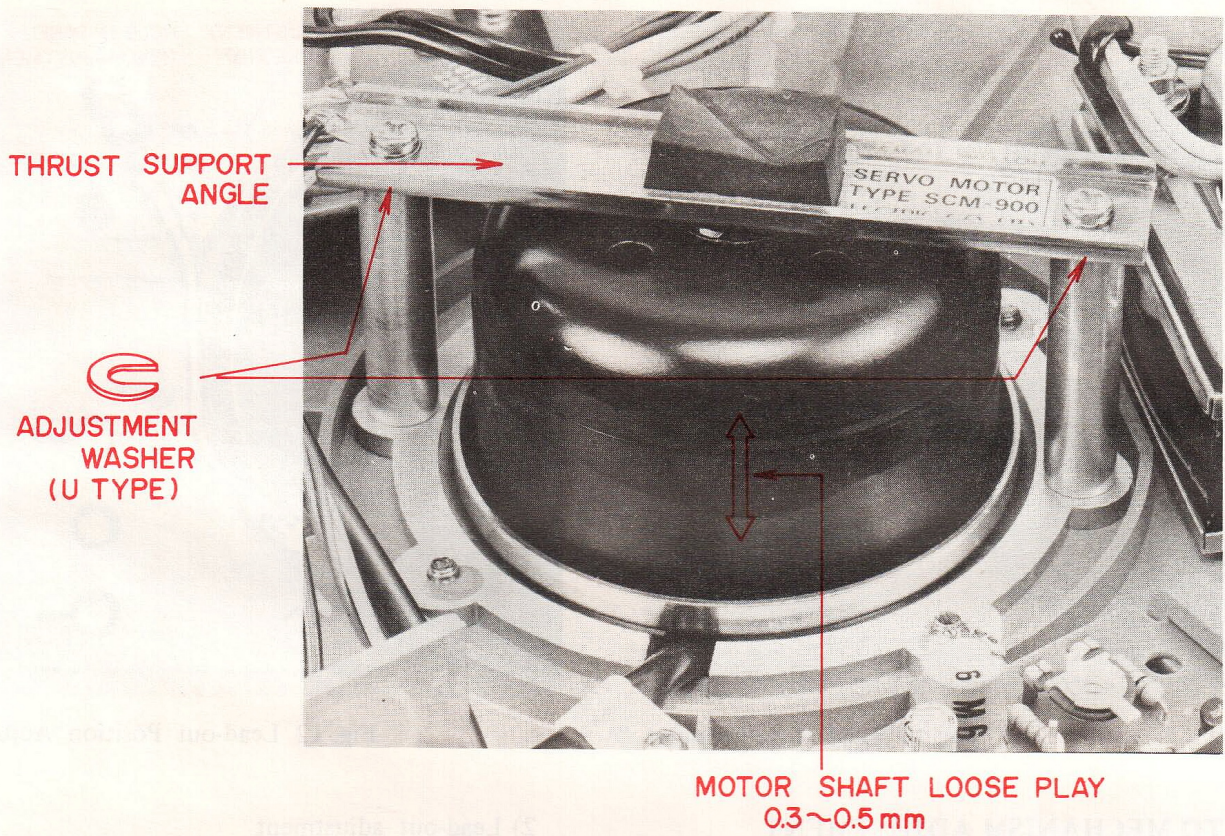

Fig. 9

5. MOTOR SHAFT LOOSE PLAY ADJUSTMENT (Refer to Fig. 9)

Adjust the U-type adjustment washer so that the outer rotor of the motor moves freely by 0.3 to 0.5 mm when shifter up and down with a hand.

6. TONE ARM LIFTER HEIGHT ADJUSTMENT

This adjustment is performed at the factory using the AKAI Model APC-5 cartridge. However, when another type of cartridge is employed, make sure that the clearance between the stylus tip and the disc record surface exceeds 4 mm when the tone arm is raised with the manual arm lifter. If this is not the case, loosen the arm lifter fixing screw indicated in Fig. 10 using a minus screwdriver, provide a clearance in excess of 4 mm, then retighten the fixing screw.



Fig. 10

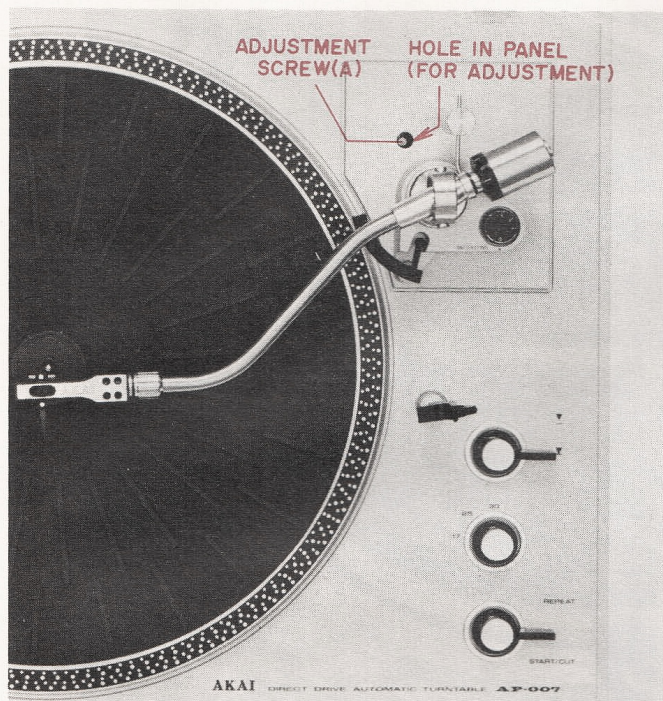

Fig. 11 Lead-in Adjustment

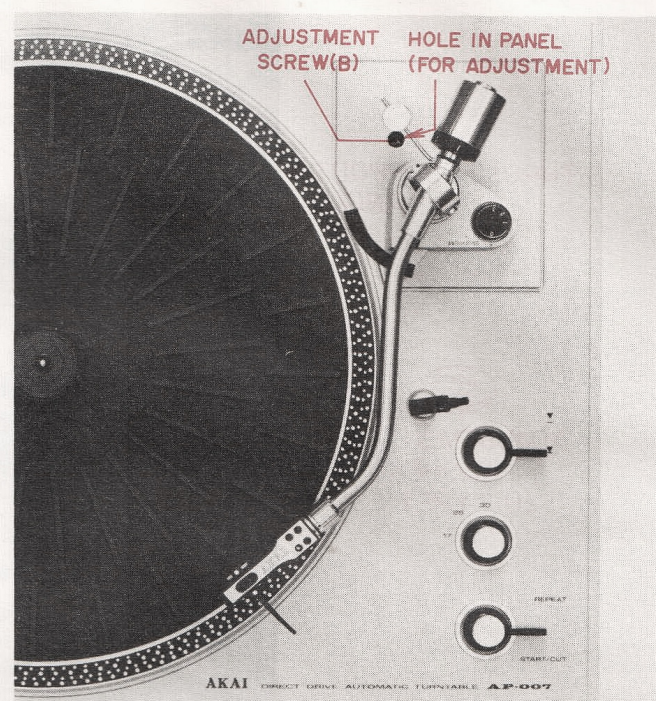

Fig. 12 Lead-out Position Adjustment

7. AUTO MECHANISM ADJUSTMENT

1) Lead-in adjustment

Remove the rubber cap from the tone arm stand. As illustrated in Fig. 11, when the tone arm is shifted from the tone arm rest nearly to the position where the lead-out motion starts, the adjustment screw (A) appears in the hole from which the rubber cap has been removed.

Turning the adjustment screw (A) clockwise and counterclockwise permits the lead-in position to move towards the center of the disc record and towards the outer rim of the record respectively. Therefore, lead-in position adjustment is performed by turning the adjustment screw (A) as follows:

Clockwise To move the lead-in position towards the center of the record.

Counterclockwise To move the lead-in position towards the outer rim of the record.

NOTE

1. One rotation of the adjustment screw causes the tone arm stylus tip to shift by 2 mm.
2. The unit is factory adjusted so that, when using the AKAI Model APC-5 cartridge, and 30-cm/25-cm/17-cm JIS records, the stylus descends to the record surface within the range of 293 ~ 298 ϕ , 242 ~ 247 ϕ or 168 ~ 173 ϕ (with the turntable spindle as the diameter center point). Sonosheets or records not in accordance with JIS dimension standards have entirely different lead-in positions. Therefore, when using such records, play them by manual operation instead of adjusting the lead-in position with the adjusting screw.
3. Be sure to fit the rubber cap after adjustment.

2) Lead-out adjustment

Remove the rubber cap from the tone arm stand. With the tone arm positioned slightly apart from the tone arm rest as shown in Fig. 12, the adjustment screw (B) appears in the hole from which the rubber cap has been removed. Turning the adjustment screw (B) clockwise and counterclockwise permits the lead-out position to shift towards the outer rim of the record and towards the center of the record respectively.

Therefore, lead-out position adjustment is performed by turning the adjustment screw (B) as follows:

Clockwise To shift the lead-out position towards the outer rim of the record.

Counterclockwise To shift the lead-out position towards the center of the record.

NOTE

1. One rotation of the adjustment screw causes the tone arm stylus tip to shift by 2 mm.
2. The unit is factory adjusted so that when using the AKAI Model APC-5 cartridge the stylus is led out within the range of 109 ~ 115 ϕ (with 30-cm/25-cm JIS record) and 98 ~ 106 ϕ (with 17-cm JIS record) with the turntable spindle as the diameter center point.
3. Be sure to fit the rubber cap after the adjustment.

3) SUPPLY P.C BOARD CEE Model (22143296)

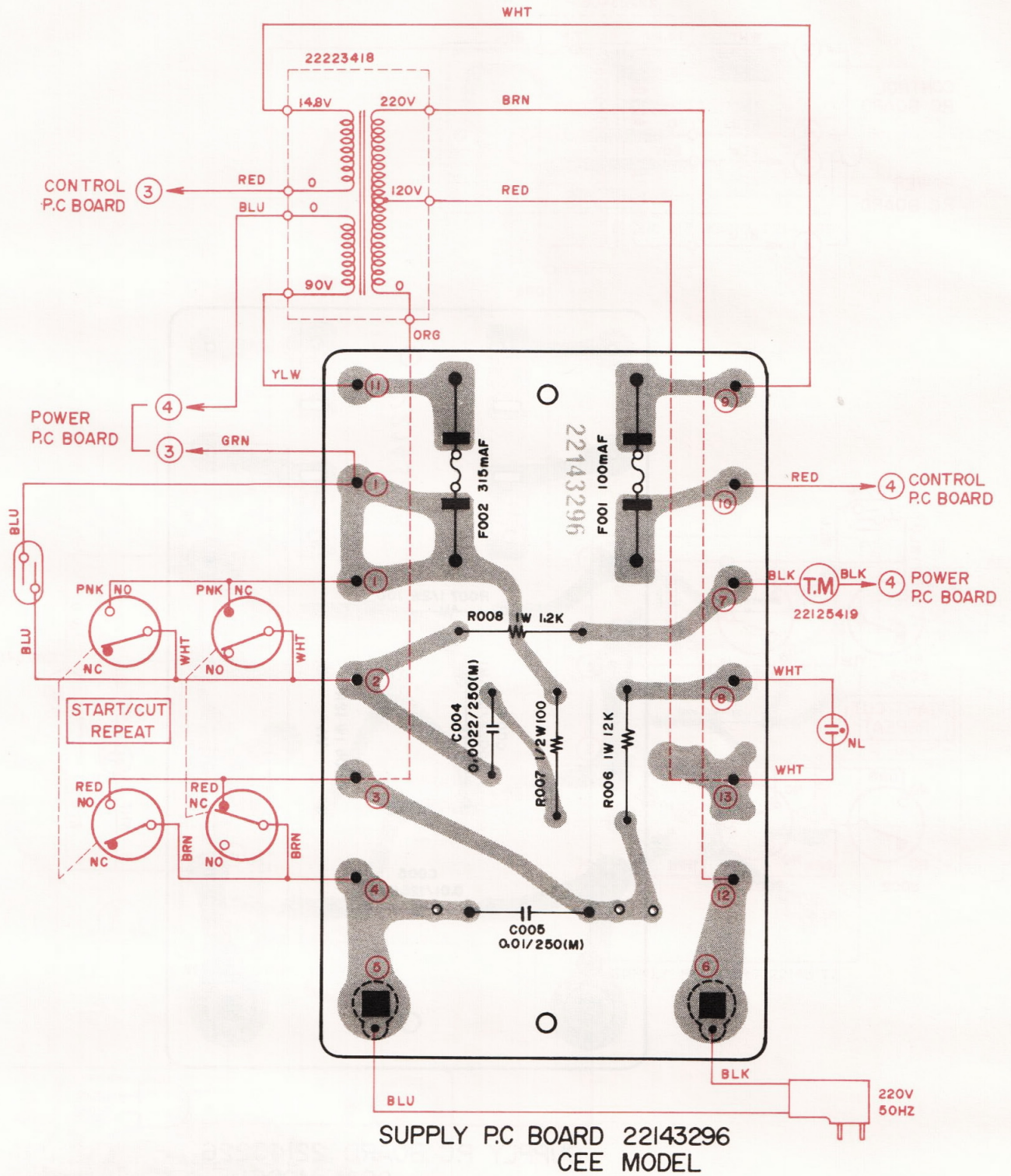

2. COMPOSITION OF VARIOUS P.C BOARDS

1) P.C BOARD EXPLODED VIEW

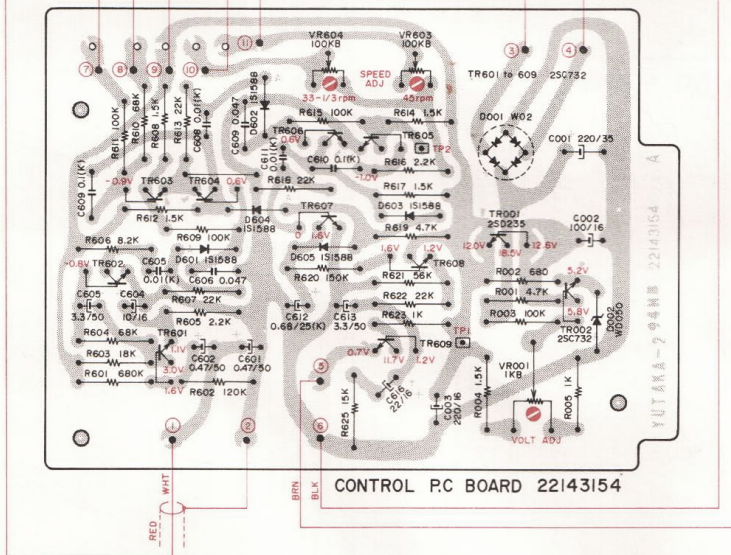
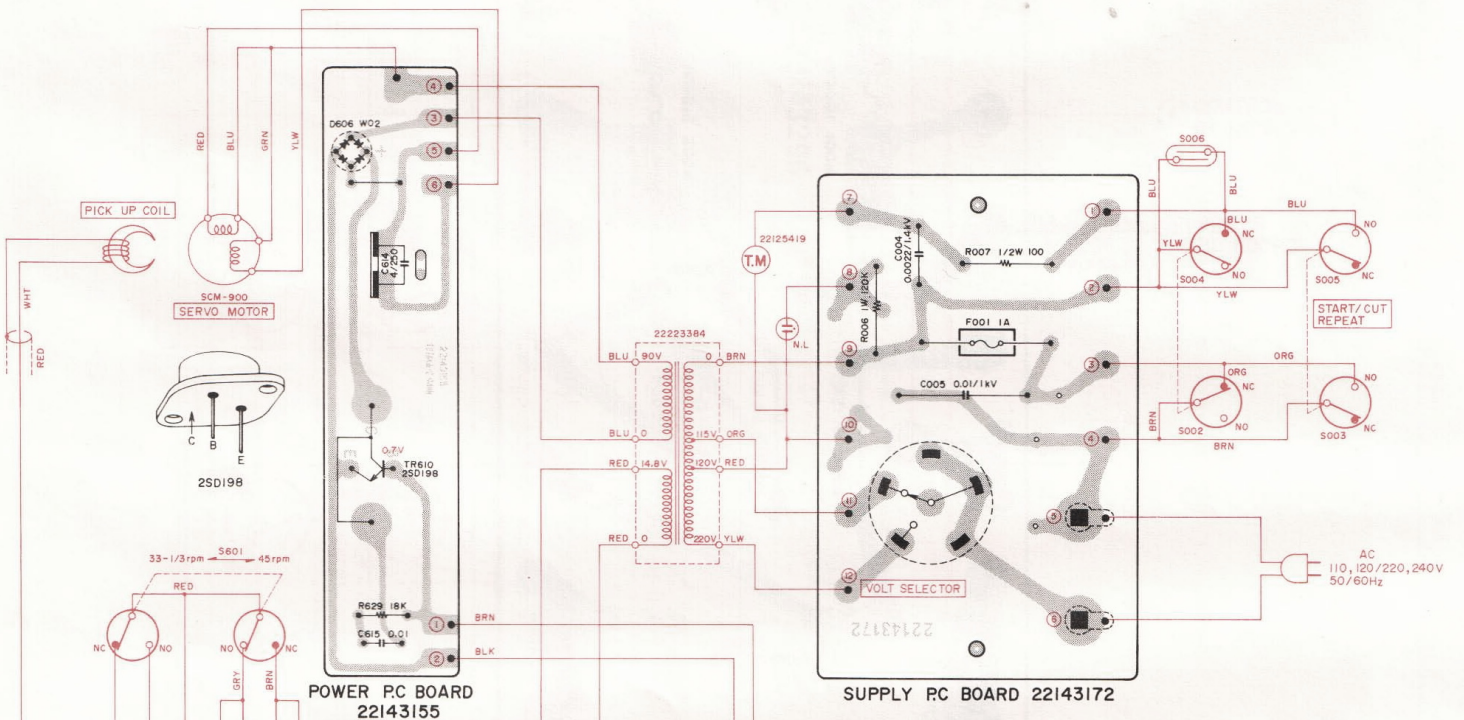
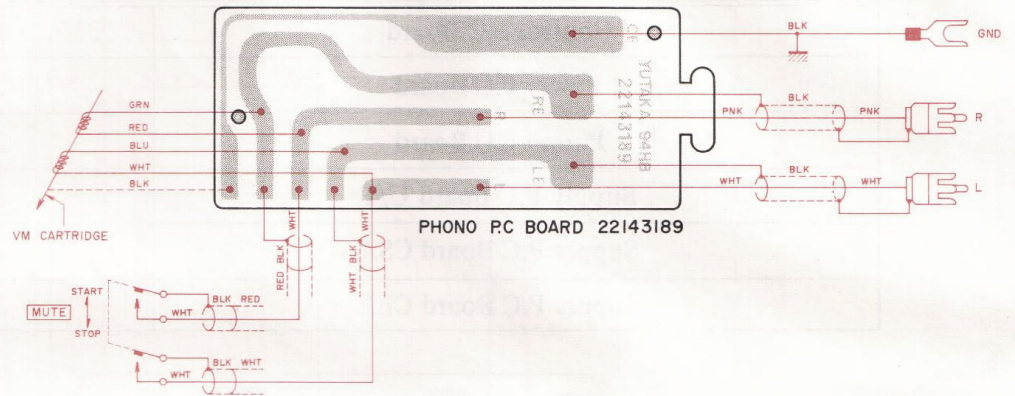

2) SUPPLY P.C BOARD CSA Model (22143226)

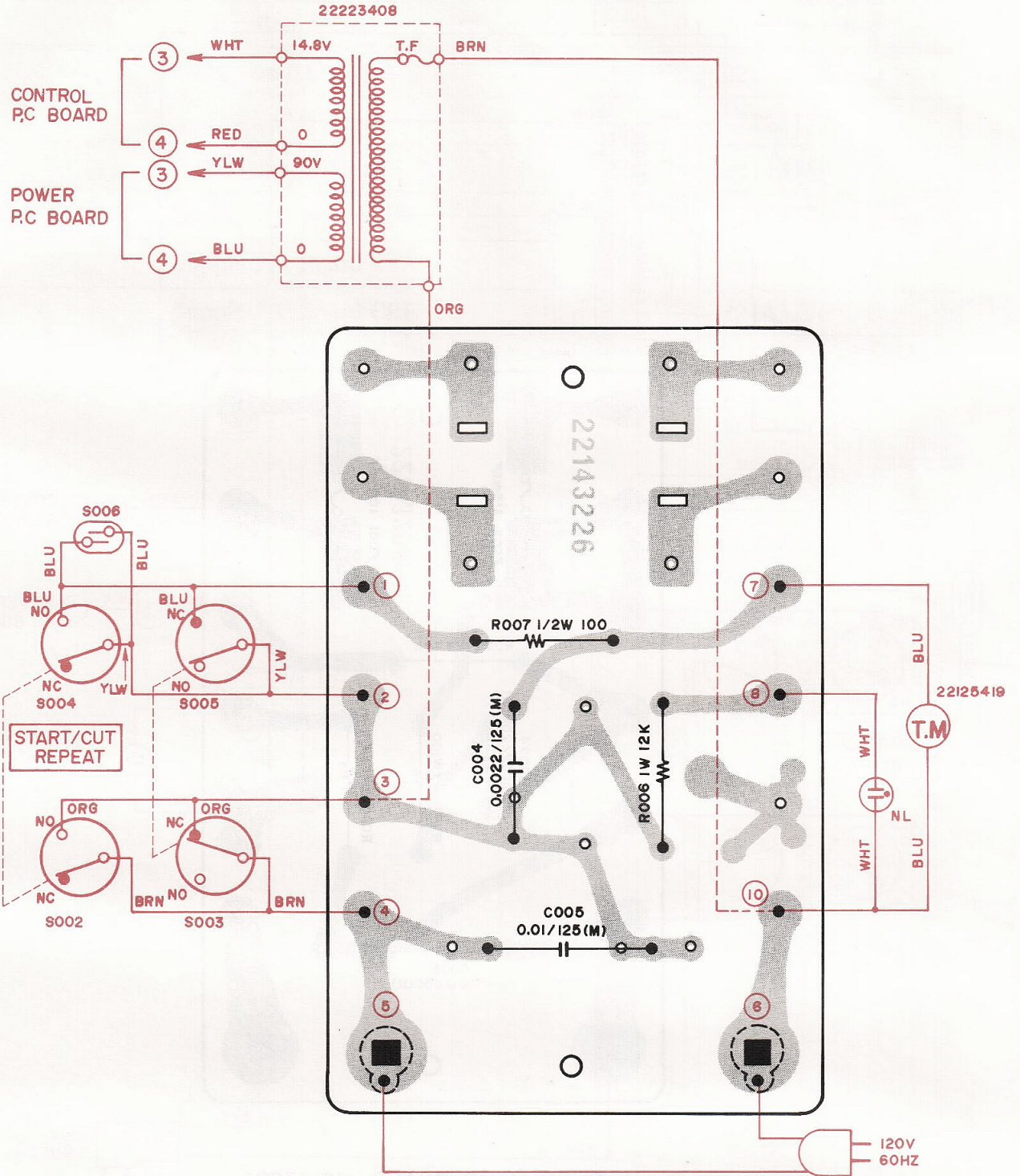

SUPPLY P.C BOARD 22143226
CSA MODEL

AP-007

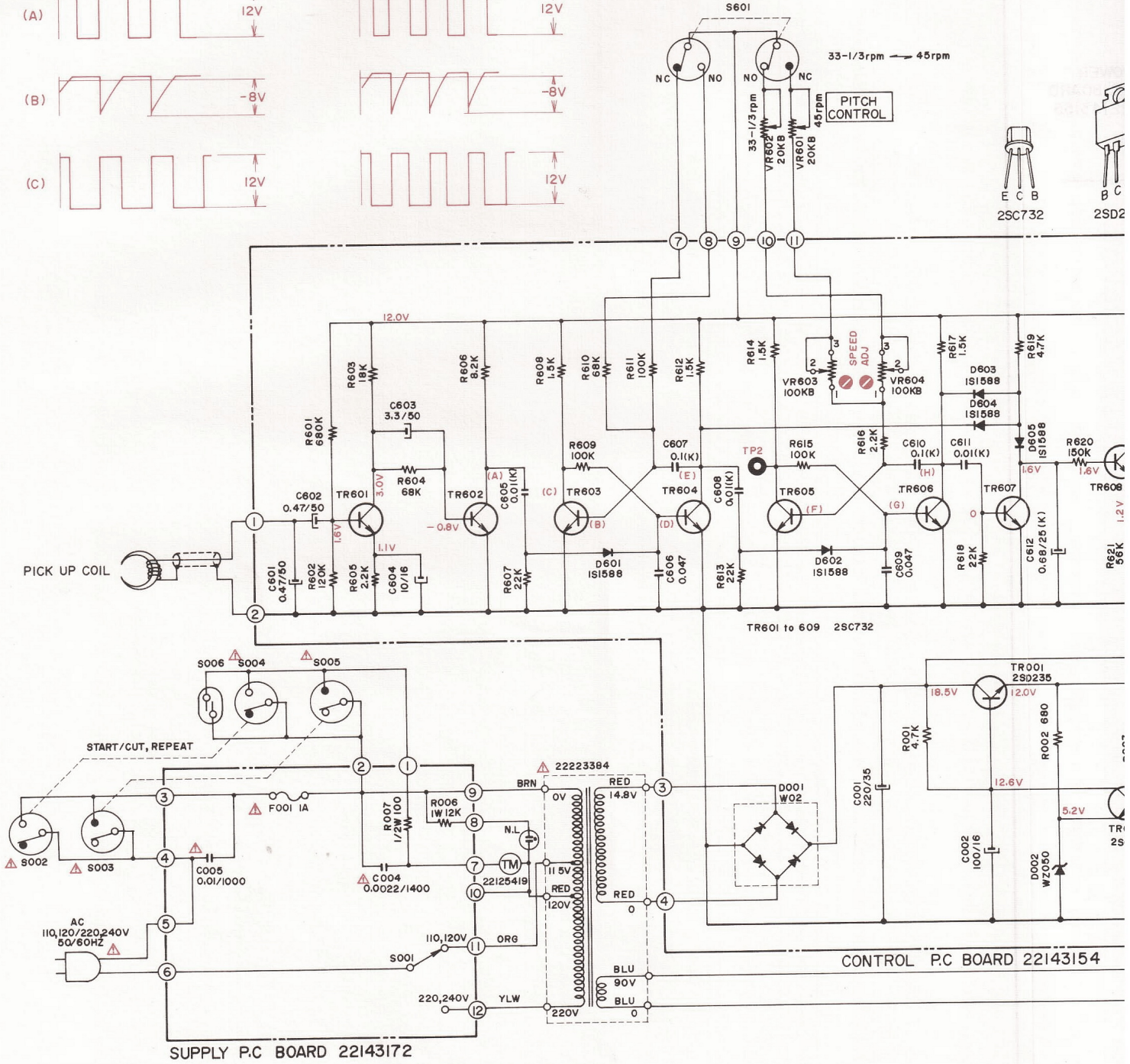
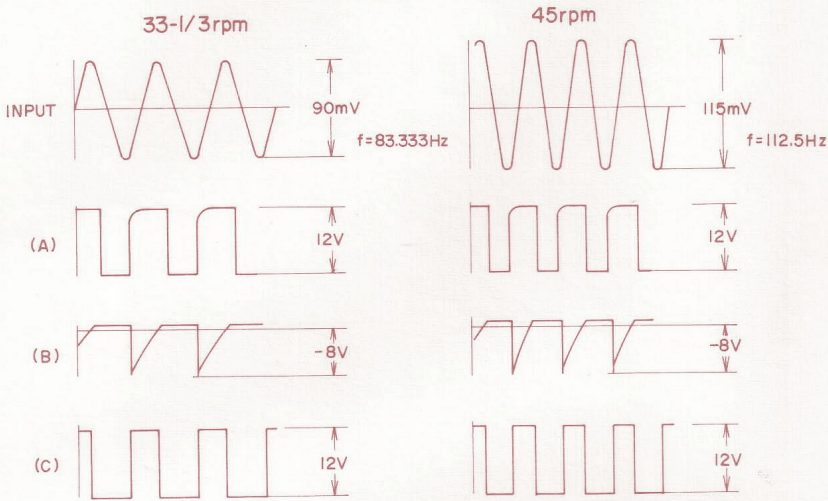

WARNING: Δ INDICATES SAFETY CRITICAL COMPONENTS. FOR CONTINUED SAFETY, REPLACE SAFETY CRITICAL COMPONENTS ONLY WITH MANUFACTURER'S RECOMMENDED PARTS

AVERTISSEMENT: Δ IL INDIQUE LES COMPOSANTS CRITIQUES DE SÛRETÉ. POUR MAINTENIR LE DEGRÉ DE SECURITE DE L'APPAREIL NE REMPLACER LES COMPOSANTS DONT LE FONCTIONNEMENT EST CRITIQUE POUR LA SECURITE QUE PAR DES PIÉCES RECOMMANDÉES PAR LE FABRICANT

MARCO
A804

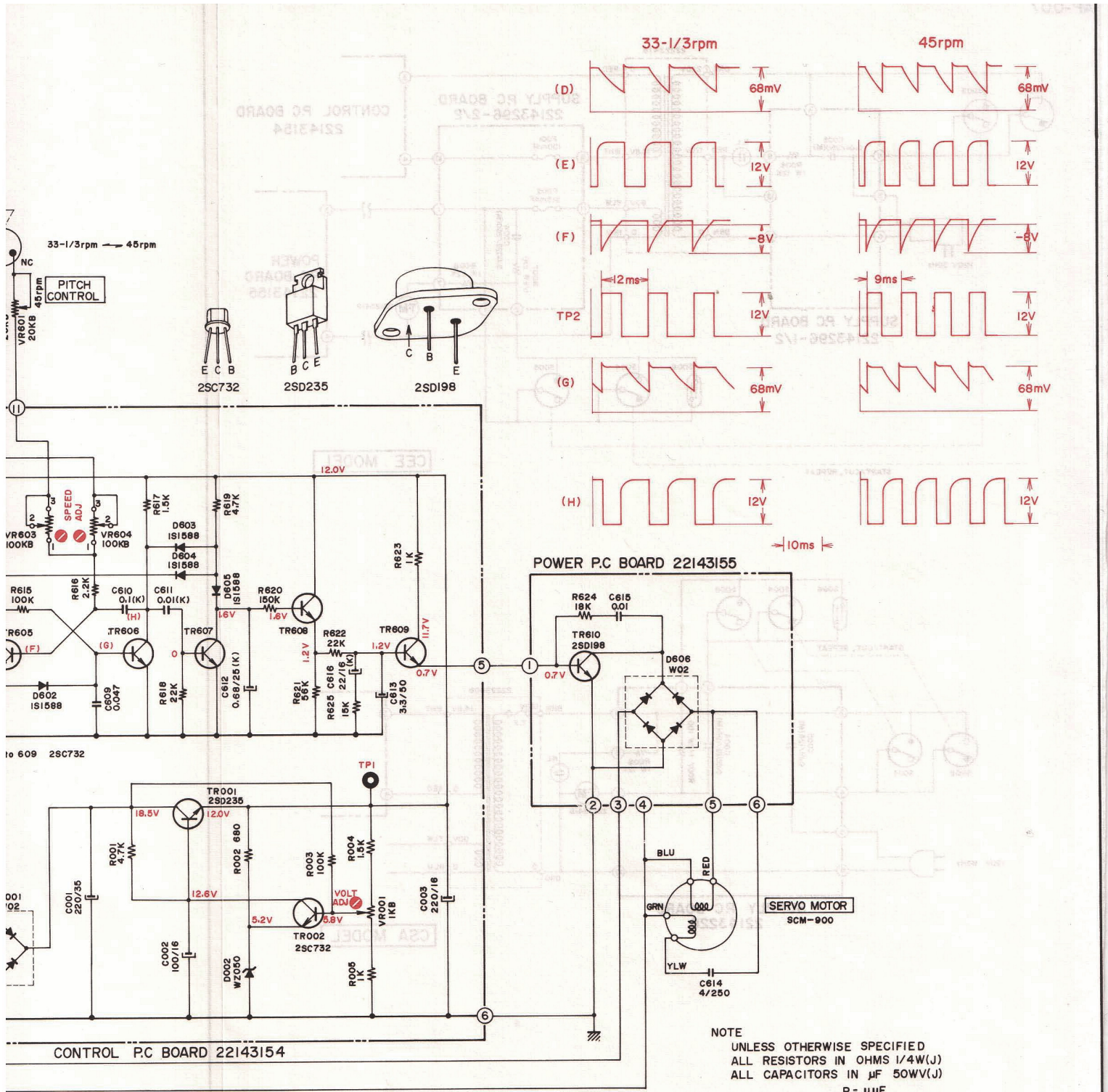

AP-007
SCHEMATIC DIAGRAM
NO.2-1 1541402A

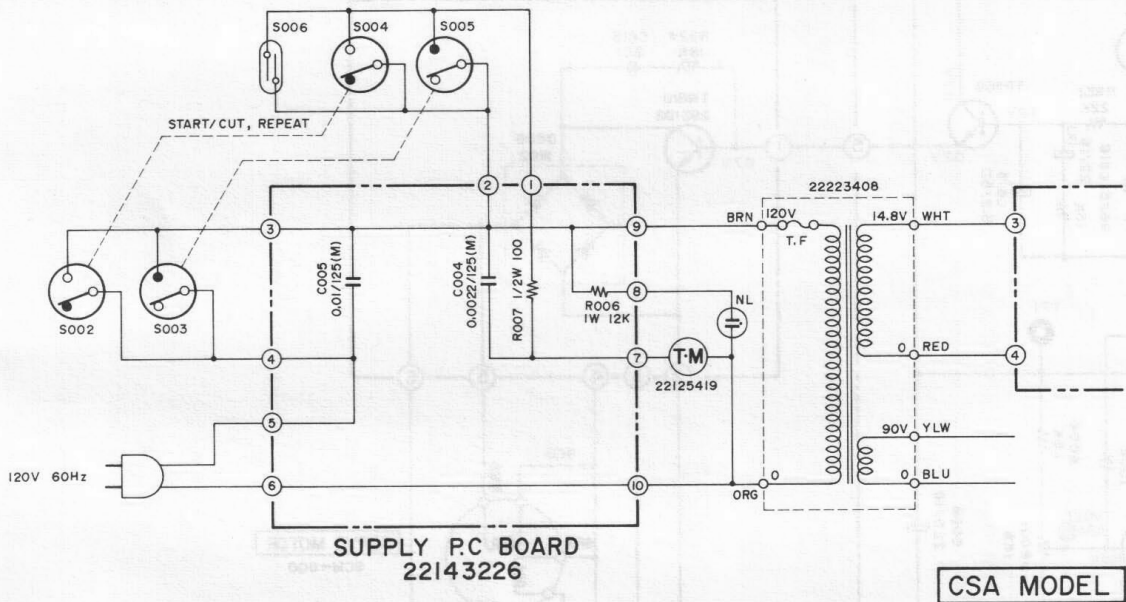
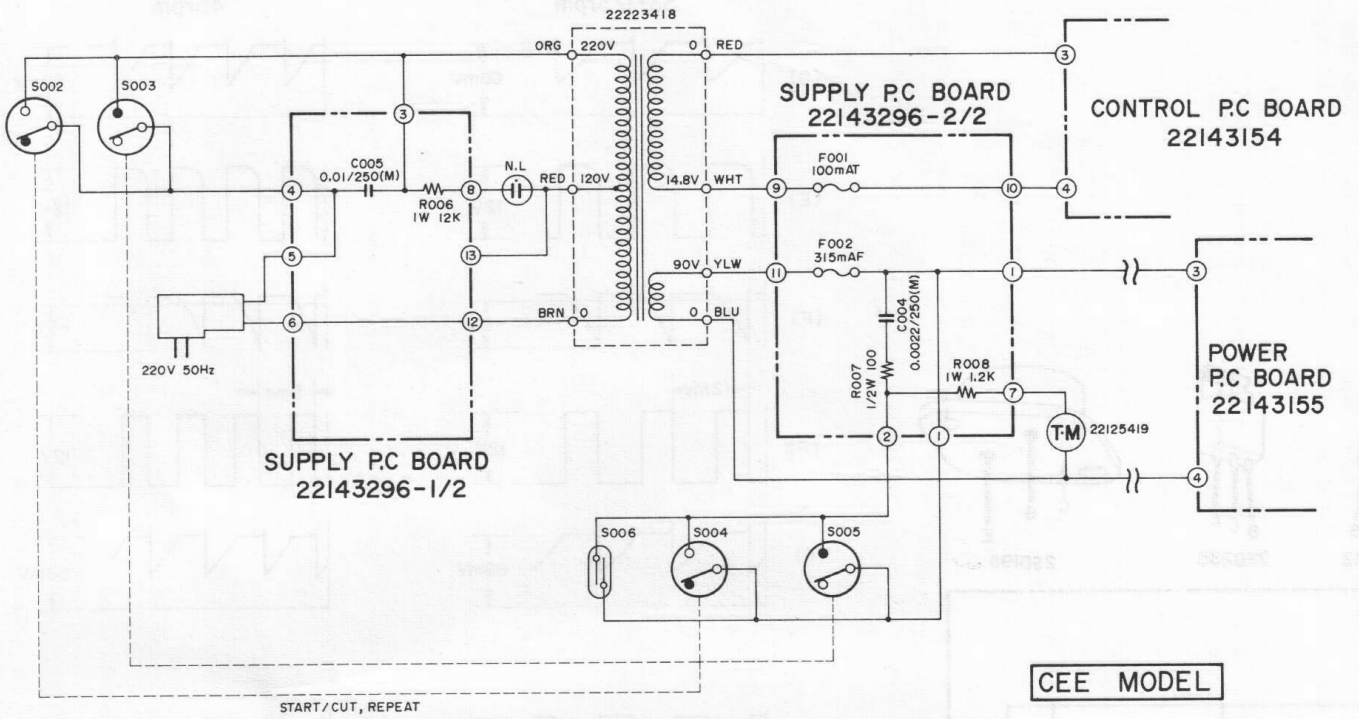

NOTE
UNLESS OTHERWISE SPECIFIED
ALL RESISTORS IN OHMS (R/W)
ALL CAPACITORS IN MICROFARADS (M)