

SERVICE MANUAL

expert

FD-710 MK2

Stereo Cassette Deck

SPECIFICATIONS

Track System	4-track 2-channel, stereo recording and playback
Tape Speed	1-7/8 i.p.s. (4.75 cm/sec.)
Wow and Flutter	0.07% (WRMS)
Frequency Response	30–18,000Hz ±3dB (Metal tape) 30–18,000Hz ±3dB (CrO ₂ tape) 30–14,000Hz ±3dB (Normal tape) (Dolby NR off)
Signal-to-Noise Ratio	53dB (Dolby NR off, CrO ₂ or Metal tape, CCIR/ARM weighted 1kHz) The S/N is improved by 8dB with Dolby NR on.
Total Harmonic Distortion	1.8% (at 1kHz, 0VU)
Erase Ratio	65dB (SRL, +10dB)
Bias Frequency	85kHz
Fast Forward and Rewind Time	70 seconds (C-60 tape)

Input Sensitivity/Impedance	
MIC	0.25mV/12 kohms
LINE	80mV/25 kohms
DIN	0.2mV/1 kohms
Output Level (at Dolby level)	
LINE	350mV
HEADPHONES	750mV

GENERAL

Power Consumption	19 watts
Power Supply	AC 110/220V, 50/60Hz
Dimensions	442(W) x 354(D) x 133(H) mm
Weight (Net)	7.2kg (15.9 lbs.)
Accessory	Shielded Audio Cables (2).

* DOLBY NR

- Dolby NR under license from Dolby Laboratories.
- The word "DOLBY" and Double-D-Symbol are trademarks of Dolby Laboratories.

Specifications and design are subject to change without notice.

ALIGNMENT PROCEDURE

Note: Set the position of REC. LEVEL to MAX. REC. BALANCE to center, TIMER, MEMORY and Dolby NR to OFF and INPUT to LINE for all alignments.

Step	Controls to be positioned	Input connection	Output Connection	Adjust	Adjust For
HEAD AZIMUTH					
1	BIAS NORMAL EQ 120 Function . . . PLAY	Test Tape MTT-114 (AZIMUTH 10kHz)	LINE OUT	AZIMUTH Screw (See Fig. A)	MAXIMUM
TAPE SPEED					
2	SAME AS STEP 1	Test Tape MTT-111D (FLUTTER 3kHz)	LINE OUT	Speed Control Screw (See Fig. B)	-0.5% ~ 2%
VU METER					
3	BIAS NORMAL EQ 120 Function . . . REC	LINE IN 400Hz 150mV	Live/GND TP805/605 (L) TP806/606 (R)	REC. LEVEL REC. BALANCE	580mV
4	SAME AS STEP 3	SAME AS STEP 3	VU METER	SVR401 (L) SVR402 (R)	DOLBY LEVEL (+3dB) (double D mark position) (See Fig. C)
PLAYBACK LEVEL					
5	SAME AS STEP 1	Test Tape MTT-150 (DOLBY LEVEL CALIBRATION TONE 200nWb/m)	Live/GND TP805/605 (L) TP806/606 (R)	SVR601 (L) SVR602 (R)	580mV
BIAS TRAP					
6	BIAS METAL EQ 70 Function . . . REC		Live/GND TP601/605 (L) TP602/606 (R)	L631 (L) L632 (R)	MINIMUM
RECORDING LEVEL CALIBRATION					
7	SAME AS STEP 3	LINE IN 400Hz 50mV Test Tape CS-10 (Blank)	LINE OUT	REC. LEVEL REC. BALANCE	240mV
8	SAME AS STEP 1	CS-10 (Recorded in step 7)	LINE OUT	SVR631 (L) SVR632 (R)	240mV
BIAS VOLTAGE					
9	SAME AS STEP 3		Live/GND TP603/605 (L) TP604/606 (R)	SVR681 (L) SVR682 (R)	Approx. 4.5mV
10	BIAS EXTRA (CrO ₂) EQ 70 Function . . . REC		SAME AS STEP 9	SVR684	Approx. 7mV
11	SAME AS STEP 6		SAME AS STEP 9	SVR683	Approx. 15mV
The Bias Voltages indicated in the above table do not necessarily provide the best frequency response for the unit under test. Further adjustment may be required to obtain optimum high frequency response.					

Fig. A (Front)

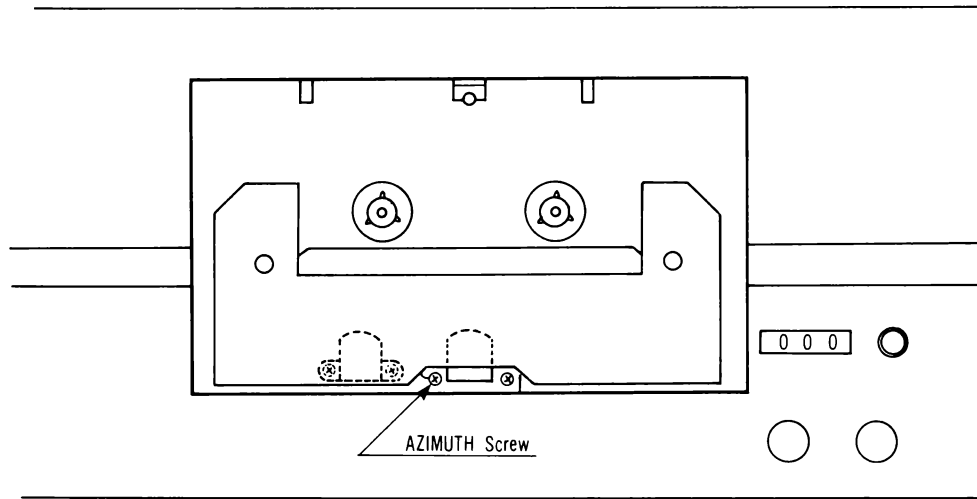

Fig. B (Rear)

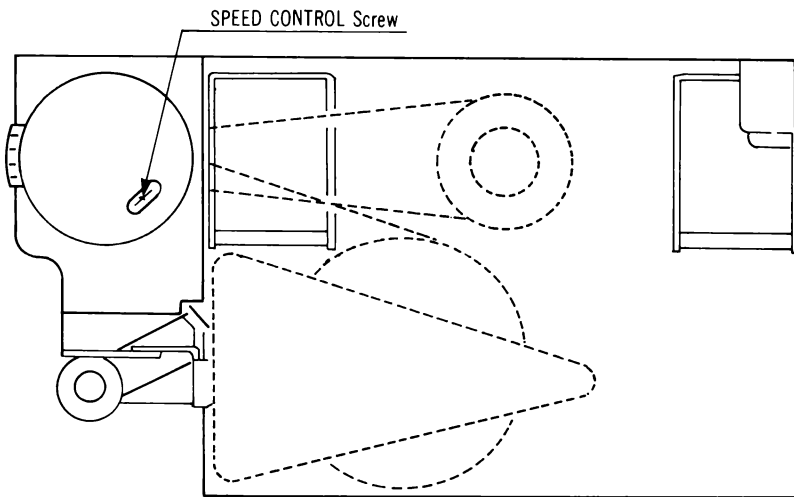
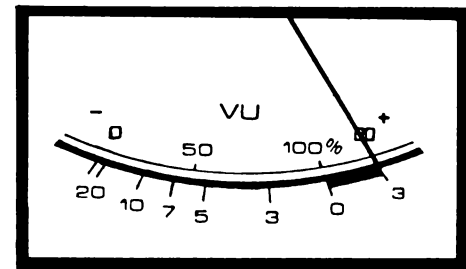
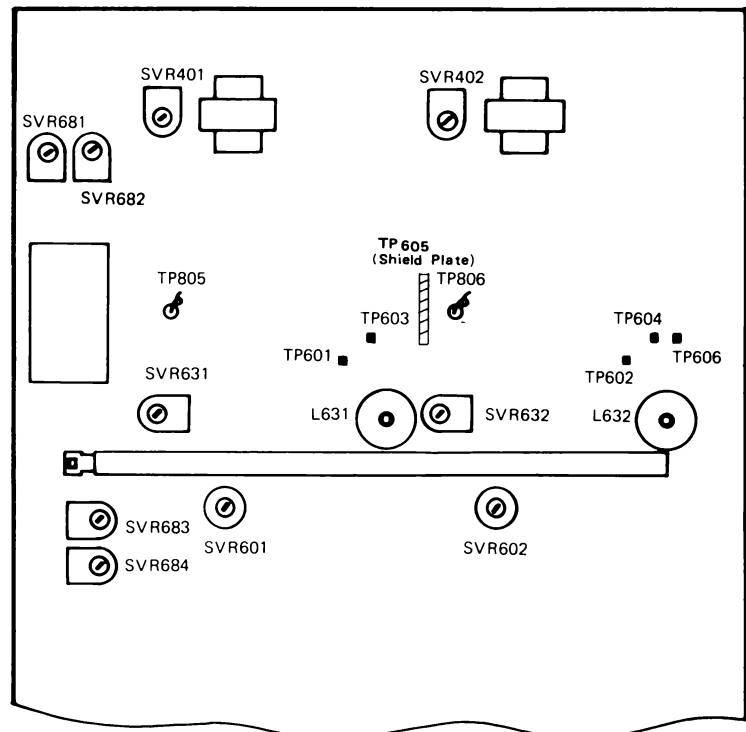

Fig. C



ALIGNMENT POINT



EQ, DOLBY NR, REC AMP. BOARD (DAM-301)

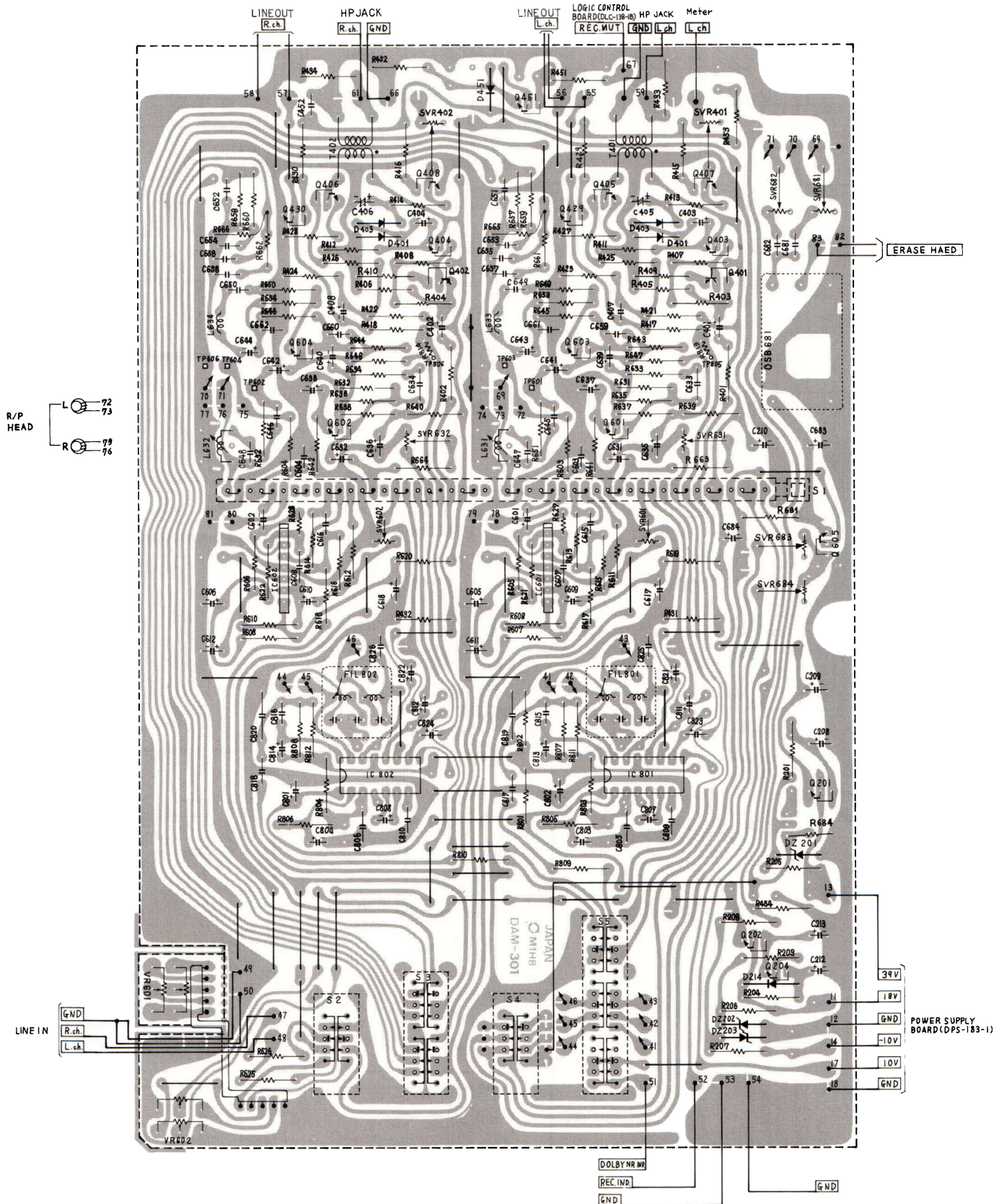

LOGIC CONTROL BOARD (DLC-138-1B)

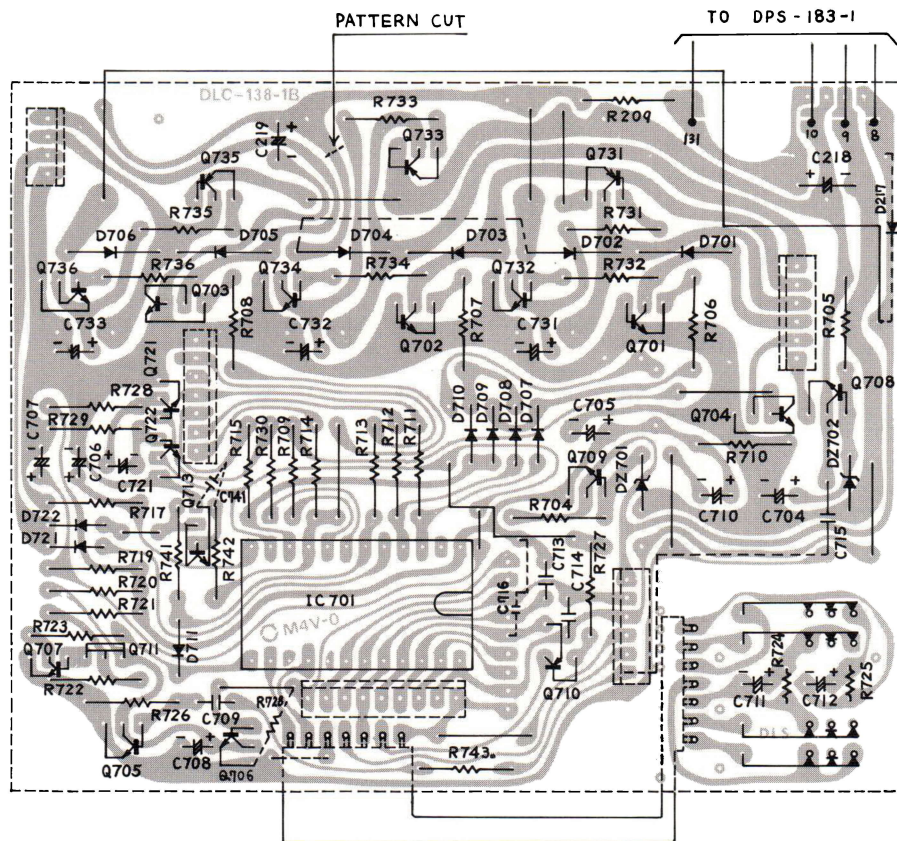

POWER SUPPLY BOARD (DPS-183-1)

DIN AMP. BOARD (DDA-167A)

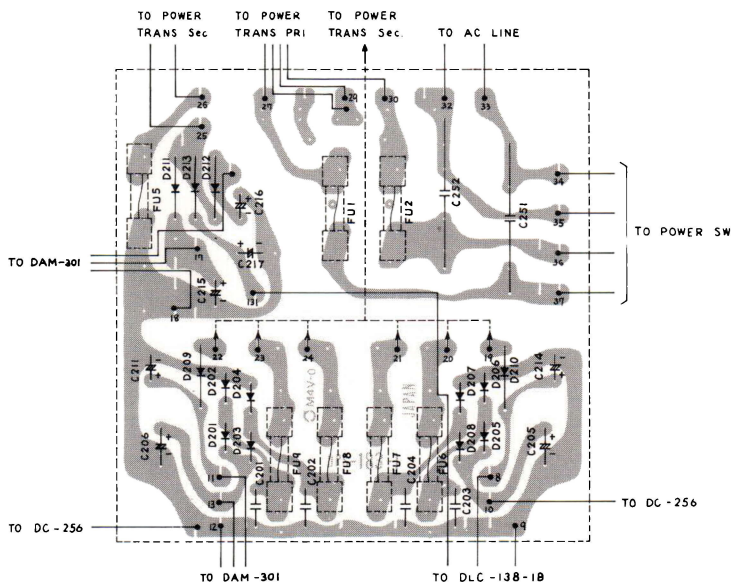

TO EQ. DOLBY NR, REC AMP BOARD (DAM-301)

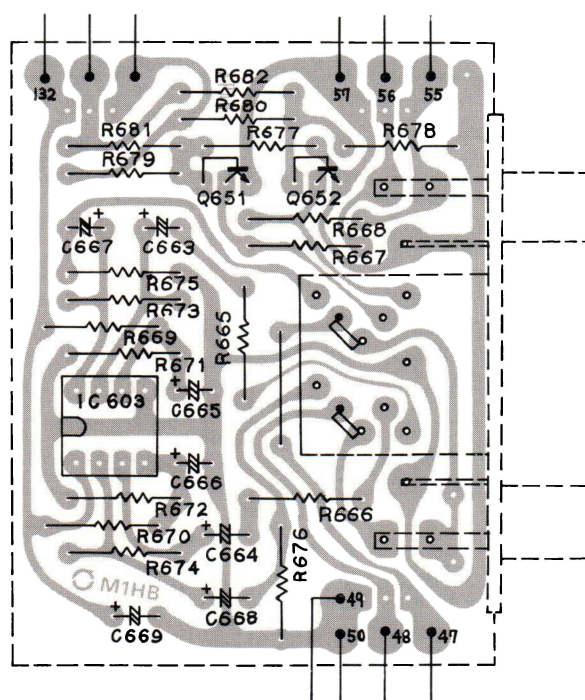

TO EQ. DOLBY NR, REC AMP BOARD (DAM-301)

PARTS LIST

Part No.	Description	Symbol No.	Q'ty a set
INTEGRATED CIRCUIT & TRANSISTORS			
TC9121P	LSI	IC701	1
DN838	Hall IC	IC702	1
TA7122AP or TA7122BP	IC	IC601, 602	2
μ PC4558	IC	IC603	1
NE646BN	IC	IC801, 802	2
2SA564(QR)	Transistor	Q710	1
2SA963(QR)	Transistor	Q731, 733, 735	3
2SC828(QR)	Transistor	Q204, 401~408, 429, 430, 451, 601~604, 651, 652, 705~707, 713, 721, 722, 732, 734, 736	27
2SC1383(QR)	Transistor	Q202, 704, 709	3
2SC2209(QR)	Transistor	Q201, 701~703, 708, 605	6
2SD592ANC(QR)	Transistor	Q708	1
2SD389(QR)	Transistor	Q250	1
N13T1	P.U.T.	Q711	1
DIODES			
1S188FM or 1N60 or 20A90	Germanium Diode	D401~404	4
1S1555 or MA150	Silicon Diode	D451, 707~711, 721, 722	8
W03B or 1N4002	Silicon Diode	D201~204, 209, 211~214, 701~ 706	15
1N4002	Silicon Diode	D210, 216, 217	3
GP-15B	Silicon Diode	D205~208	4
HZ6-3-A	Zener Diode	DZ203	1
HZ9-2-B	Zener Diode	DZ701	1
HZ12-3-C	Zener Diode	DZ202, 702	2
HZ24-3	Zener Diode	DZ201	1
GL-9PR2	LED	LED701~705	5
CONTROLS			
EWK-HWA332A24	Potentiometer	VR601	1
EWK-G4A323703	Potentiometer	VR602	1
EVT R4S00B24	Carbon Trimmer	SVR601, 602	2
20k Ω (B), 8 ϕ	Carbon Trimmer	SVR684	1
5k Ω (B), 8 ϕ	Carbon Trimmer	SVR401, 402	2
10k Ω (B), 8 ϕ	Carbon Trimmer	SVR631, 632, 683	3
50k Ω (B), 8 ϕ	Carbon Trimmer	SVR681, 682	2
SWITCHES			
ESD-81541	Slide Switch	S1	1
SW4235012	Lever Switch	S2, 4	2
SW4435013	Lever Switch	S3	1
SW4635021	Lever Switch	S5	1
ESL-2428	Lever Switch	S6, 7	2
LSA-1139	Leaf Switch	S12	1
HKW0141-01-010	Function Button Unit Ass'y	S11	1
ESB-7097	AC ON/OFF Switch	S13	1
BIAS OSC. UNIT			
53T-004A	Bias OSC. Unit	OSB681	1
FILTER			
12A-1120	Filter, 19kHz	FIL801, 802	2
COILS & TRANSFORMERS			
NPT-0435S	Power Transformer		1
162005	Output Transformer	T401, 402	2
1.8mH (MC-125R)	Variable Inductor	L631, 632	2
1.2mH (RC-875)	Inductor	L633, 634	2

Part No.	Description	Symbol No.	Q'ty a set
CONNECTORS & TERMINALS			
HLJ-0249-01-02	Headphone Jack		1
HLJ-0264-01-03	Mic Jack		2
CS728-1-2	DIN Socket		1
N41572	4-Pin Jack		1
MC03-021	Micro Connector Ass'y, 3 Hole		1
MC06-014	Micro Connector Ass'y, 6 Hole		1
MC07-015	Micro Connector Ass'y, 7 Hole		1
MC07-016	Micro Connector Ass'y, 7 Hole		1
MC09-017	Micro Connector Ass'y, 9 Hole		1
171825-3	Micro Plug, 3-Pin		1
171825-6	Micro Plug, 6-Pin		1
171825-7	Micro Plug, 7-Pin		2
171825-9	Micro Plug, 9-Pin		1
SR3P-4	Strain Relief, Line Cord		1
PC-002	Audio Cable		2
ACC-010	Line Cord		1
SOLENOID			
180005	Solenoid	SL3	1
FUSES, METERS & LAMPS			
FU-522015T	Fuse (200mA)	FU1, 2	2
FU-522025T	Fuse (2A)	FU5	1
FU-523125T	Fuse (3.5A)	FU6, 7	2
FU-525015T	Fuse (500mA)	FU8, 9	2
KL-258T-6	VU Meter		2
BQ044-23633A	Lamp	LA901, 902	2
PL12303003A	Lamp	LA905	1
FUSE HOLDERS			
S-N5053	Fuse Holder		14
RESISTORS			
$\frac{1}{4}$ W 3.3k Ω	Metal Film	R811, 812	2
$\frac{1}{2}$ W 680 Ω	Carbon	R681	1
1W 5.6 Ω	Carbon or Metal Film	R209	1
CAPACITORS			
HE40SJSL200K	Ceramic	C607, 608, 659, 660	4
HE70SJSL201K	Ceramic	C647, 648, 681, 682	4
HE70SJSL271K	Ceramic	C825, 826	2
HE70SJYF103Z	Ceramic	C713~716	4
HE13SJYF473Z	Ceramic	C201~204, 684	5
50V 100pF(K)	Styrol	C603, 604	2
50V 560pF(K)	Styrol	C645, 646	2
ECNC4A 103M	Oil	C251, 252	2
50V 0.0047 μ F	Mylar (\pm 5%)	C815, 816	2
50V 0.0056 μ F	Mylar (\pm 5%)	C649, 650, 817, 818	4
50V 0.0068 μ F	Mylar (\pm 5%)	C615, 616, 651, 652, 655, 656	6
50V 0.0082 μ F	Mylar (\pm 5%)	C661, 662	2
50V 0.027 μ F	Mylar (\pm 5%)	C653, 654, 819, 820	4
50V 0.033 μ F	Mylar (\pm 5%)	C657, 658	2
50V 0.1 μ F	Mylar (\pm 5%)	C805, 806	2
50V 0.033 μ F	Mylar (\pm 20%)	C452, 709	2
ECEA50MR33	Electrolytic (MS)	C803, 804	2
ECEA50MR47R	Electrolytic (MSR)	C811, 812	2
ECEA16M10R	Electrolytic (MSR)	C601, 602	2
10TW 47 μ F	Electrolytic	C216	1

PARTS LIST

Part No.	Description	Symbol No.	Q'ty a set
10TW 100 μ F	Electrolytic	C637, 638	2
10TW 220 μ F	Electrolytic	C215	1
10TW 470 μ F	Electrolytic	C611, 612, 217	3
10TW 33 μ F	Electrolytic	C407, 408, 643, 644	4
10TW 1000 μ F	Electrolytic	C219	1
10TW 2200 μ F	Electrolytic	C218	1
16TW 4.7 μ F	Electrolytic	C667, 668	2
16TW 10 μ F	Electrolytic	C212, 403, 404, 710, 807, 813, 814, 821, 823, 824, 822, 808, 665, 666, 741	15
16TW 0.22 μ F	Electrolytic	C631, 632	2
16TW 47 μ F	Electrolytic	C704	1
16TW 100 μ F	Electrolytic	C705	1
16TW 220 μ F	Electrolytic	C802	1
16TW 1000 μ F	Electrolytic	C214	1
25TW 3.3 μ F	Electrolytic	C707	1
25TW 1 μ F	Electrolytic	C663, 664	2
25TW 4.7 μ F	Electrolytic	C401, 402, 641, 642	4
25TW 10 μ F	Electrolytic	C213, 609, 610, 639, 640	5
25TW 47 μ F	Electrolytic	C208, 605, 606, 635, 636, 669	6
25TW 100 μ F	Electrolytic	C210, 617, 618, 683, 801	5
25TW 220 μ F	Electrolytic	C209, 211	2
35TW 220 μ F	Electrolytic	C250	1
35TW 100 μ F	Electrolytic	C731, 732, 733	3
35TW 1000 μ F	Electrolytic	C205	1
50TW 0.1 μ F	Electrolytic	C721	1
50TW 1 μ F	Electrolytic	C405, 406, 684, 706, 711, 712	6
50TW 2.2 μ F	Electrolytic	C708	1
50TW 220 μ F	Electrolytic	C206	1
APPEARANCE PARTS			
N10148	Front Panel		1
N20395-BK	Cass' Holder		1
N41232-GY1	Side Cap, Right		1
N41233-GY1	Side Cap, Left		1
N41281-S	Push Button, Power		1

Part No.	Description	Symbol No.	Q'ty a set
N41265	Push Button, Eject		1
N30254A	Knob, Lever		6
N41291	Reset Button		1
N41661	Knob 21	Rec. Balance	1
N41660	Knob 44	Rec. Level	1
N30248A	Cass' Compartment		1
N30251	Meter Plate		1
N41266	Top Cover	Cass' Holder	1
N41293	Alum. Plate-DB	Logic Cont.	1
N41443	Meter Window		1
N41250-T	Cass, Window		1
N41109	Counter Window		1
N20398-S	Case		1
T-C	Foot		4
MISCELLANEOUS			
CT3309F	Cass' Mechanism		1
No. 18	Mica (for Q250)		1
No. 24B	Bushing (for Q250)		1
N41471A	Heat Sink		5
N41404	Heat Sink		1
LT-CH-1xLx1	Terminal		1
N30231A	Bottom Plate		1
N41421	Shield Plate		1
N41532	Eject Hook		1
N41533	Slide Lever		1
N20395-NH	Cass' Case		1
N20382A	Meter Frame		1
N30453	Cass' Plate		1
N41380	Decoration Screw		2
N20668	Rear Chassis		1
N41282	Lamp Holder		1
N41313	Display Plate		1
N40769A	Cass' Sheet		1
PACKING MATERIAL			
N41318	Poly. Bag	For Unit	1
N40487	Poly. Bag	For Inst. Book	1
N20389	Pad, Right		1
N20390A	Pad, Left		1
N41424	Pad, Top		1
N41662	Carbon		1
N42098	Inner Carton		1

- NOTE: 1. Part orders must contain Model Number, Part Number and Description.
 2. Ordering quantity of screws and/or resistors must be multiple of 10 pcs.
 3. Resistors not detailed in parts list are all carbon type ¼ watt, with regard to the value, refer to the schematic diagram.

PARTS LIST

CASSETTE MECHANISM (CT-3309F)

Parts No.	Description	Q'ty
A0176	Drive Arm Ass'y	1
A0183	Reel Ass'y SA	1
A0194	Reel Ass'y TA	1
A0204	Drive Pulley Ass'y	1
B0831	Soft Dumper Ass'y D	1
C0390	Counter (SMP390-189)	1
C0560	Counter Belt	1
E1360	S.K Binder (SKB-1M)	2
E1451	I.C Board (IC-13)	1
E1530	Wire, Red	1
E1540	Wire, Black	1
F0130	Flywheel M	1
G1360	Connector Ass'y 6P	1
G1370	Connector Ass'y 7P	1
G1530	Hall IC (DN838)	1
G2170	R/P Head (HJ42860)	1
G2180	Erase Head (HF213152)	1
G3490	Motor (MMX-6H2LSA)	1
J0100	Pinch Roller	1
J0280	Rew. Idler A	1
J0440	Pinch Roller Arm H	1
J0462	Shaft Supporter G	1
J0740	Cass' Guide LB	1
J0750	Cass' Guide RB	1
K1632	F.F Idler Arm Ass'y H	1
K1641	F.F Action Arm Ass'y	1
K1662	Action Plate Ass'y D	1
K2095	Chassis Ass'y	1
K2103	Head Panel Ass'y	1
K2364	Sub Chassis Ass'y B	1
K2440	F.F Lever Ass'y A	1
N0250	Eject Cord F (125L)	1
P0270	Solenoid (XA-00027-19VX24)	2
Q0240	R/P Head Spring B	1
Q1992	Pinch Roller Spring H	1
Q2010	F.F Action Arm Spring A	1
Q2021	Rew. Arm Spring A	1
Q2050	Brake Arm Spring RA	1
Q2061	Brake Arm Spring LA	1
Q2081	Action Plate Spring F	1
Q2103	Drive Arm Spring A	1
Q2111	Action Lever Spring A	1
Q2142	Action Lever Spring C	1
Q2152	Action Plate Spring H	2
Q2230	Eject Cord Spring F	1
G2260	Erase Head Spring A	1
Q2313	Back Tension Spring B	1
Q2350	Eject Cord Hook D	1
S0340	Micro Switch (SS-5GL13)	2
T0220	REC. Sensor Ass'y	2
U0170	Counter Belt (1x58)	1
U0340	Rubber Cushion	3
U0600	Adjusting Screw	1
U0844	Brake L	1
U0854	Brake R	1
U0892	Reel Cap C	2
U1301	Rubber Cushion C	2
U1310	Main Belt (84 x 4 x 0.4 - 60)	1
U1500	Felt, 1 x 6 x 4	1
U1660	Drive Belt (1.3 x 72.6 - 70)	1
U2170	Rubber for Brake B	2
V2910	Collar, 2.8 x 3.8 x 5	3

Parts No.	Description	Q'ty
V3212	F.F Idler Arm Collar	1
V4300	Eject Lever Collar H	1
V5110	Motor Pulley (2 x 12.8V - 9.8RD)	1
X1920	Lug E	3
X4111	Washer	1
X4851	Pressing Metal	1
X4911	Action Arm Bracket A	1
X4971	Action Arm A	1
X4980	Head Panel Pushing Plate G	1
X5041	Rew. Arm	1
X6331	Head Panel Pushing Plate J	1
X6340	Flywheel Supporter Board Q	1
X6371	Cass' Hold Back Spring Plate J	1
X6381	Head Panel Pushing Plate K	1
X6390	Solenoid Arm Guide A	2
X6401	Solenoid Arm RB	1
X6411	Solenoid Arm LB	1
X6463	Motor Holder R	1
X6513	Soft Dumper Bracket D	1
X6520	Eject Cord Bracket A	1
X6530	Eject Cord AJ Bracket A	1
X6570	I.C Board Bracket A	1
X7220	Supporting Plate for Bracket A	2
X7370	Lock Bracket C	1
X7391	Drive Arm Pushing Plate B	1
X7860	Back Tension Bracket E	1
X8090	Micro Switch Bracket C	2
X8170	Rew. Lever D	1
01105	Pan Head Machine Screw 2.3 x 4	2
01111	Pan Head Machine Screw 2.3 x 10	2
01144	Pan Head Machine Screw 2.6 x 3	5
01151	Pan Head Machine Screw 2.6 x 10	2
01166	Pan Head Machine Screw 3 x 5	2
04085	Flat Head Machine Screw 2 x 4	1
08086	Bind Head Screw 2 x 5	1
17166	Pan Head Tapping Screw 3 x 5	1
18086	Bind Head Fine Screw 2 x 5	1
18088	Bind Head Fine Screw 2 x 7	1
19085	Screw W/Spring Washer 2 x 4	1
19145	Screw W/Spring Washer 2.6 x 4	2
19146	Screw W/Spring Washer 2.6 x 5	14
19149	Screw W/Spring Washer 2.6 x 8	2
19158	Screw W/Spring Washer 2.6 x 18	1
19166	Screw W/Spring Washer 3 x 5	4
20148	Screw W/Flat Washer 2.6 x 7	3
21046	Washer Faced Head Screw 2.6 x 4.5	2
21050	Washer Faced Head Screw 2.6 x 6.5	1
23007	Tapping Screw 2.6 x 6	3
23014	Tapping Screw 2.6 x 5	5
27026	Spring Washer M2.6	1
30126	Flat Washer 2.8 x 7.5 x 0.5	2
32201	P.S.W 2.1 x 4 x 0.13	1
32252	P.S.W 2.6 x 4.7 x 0.25	5
32255	P.S.W 2.6 x 4.7 x 0.5	3
32505	P.S.W. 5.2 x 8.0 x 0.5	1
33077	Spring Pin 3 x 16	2
35104	Rivet 2 x 3	2
36015	E Ring E-1.5	2
36020	E Ring E-2.0	7
36025	E Ring E-2.5	2
42025	Steel Ball M2.5	6

NOTE: 1. Part orders must contain Model Number, Part Number and Description.
 2. Ordering quantity of screws and/or resistors must be multiple of 10 pcs.

EXPLODED DIAGRAM

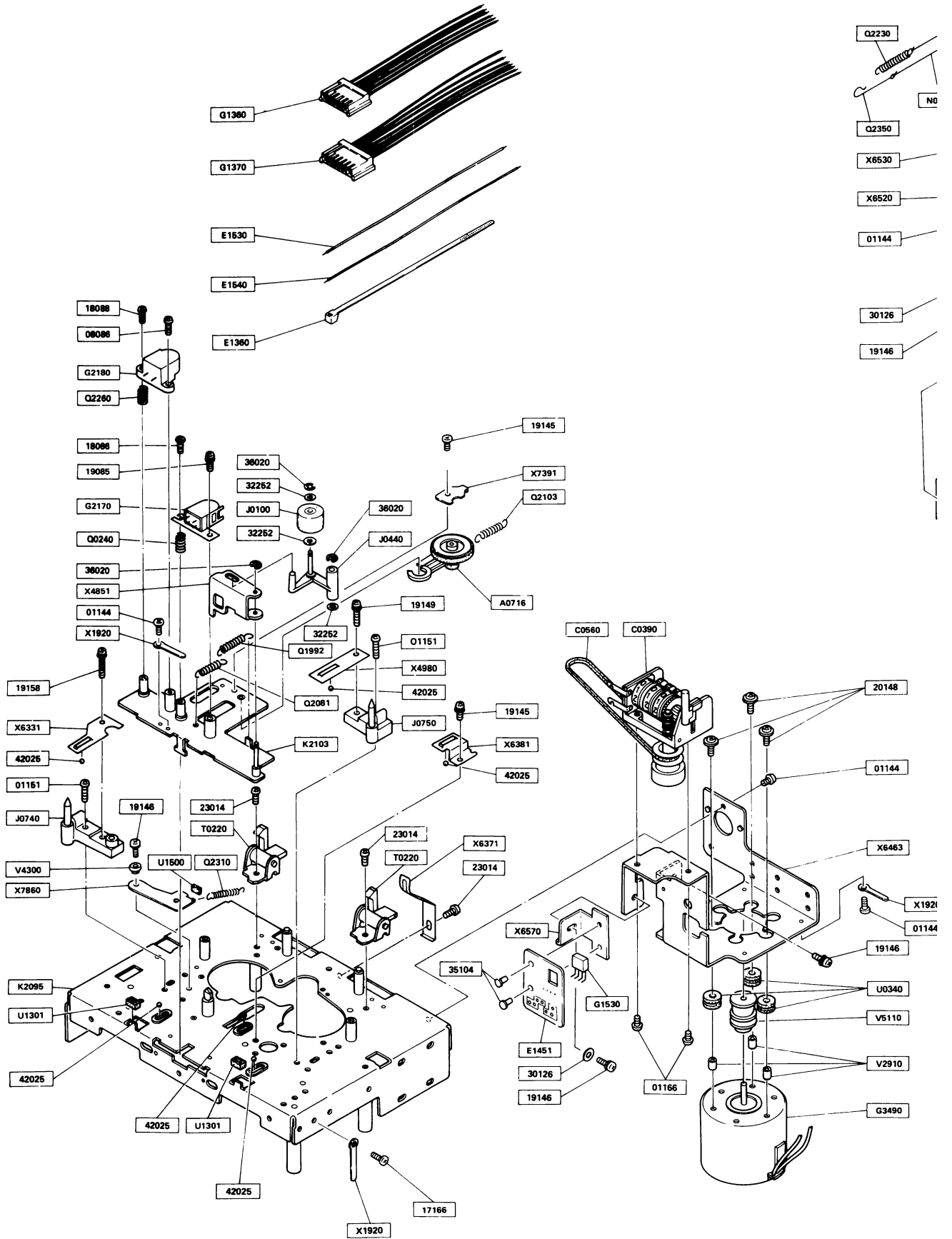

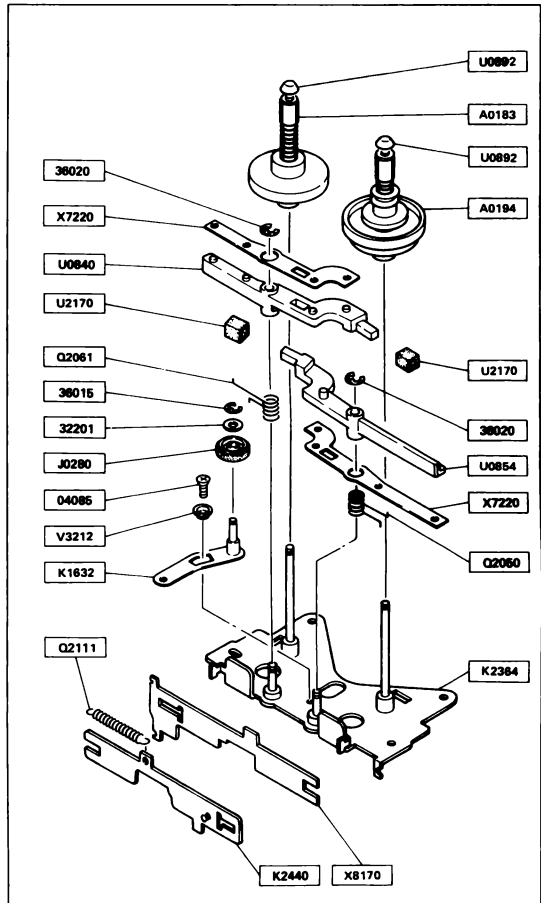
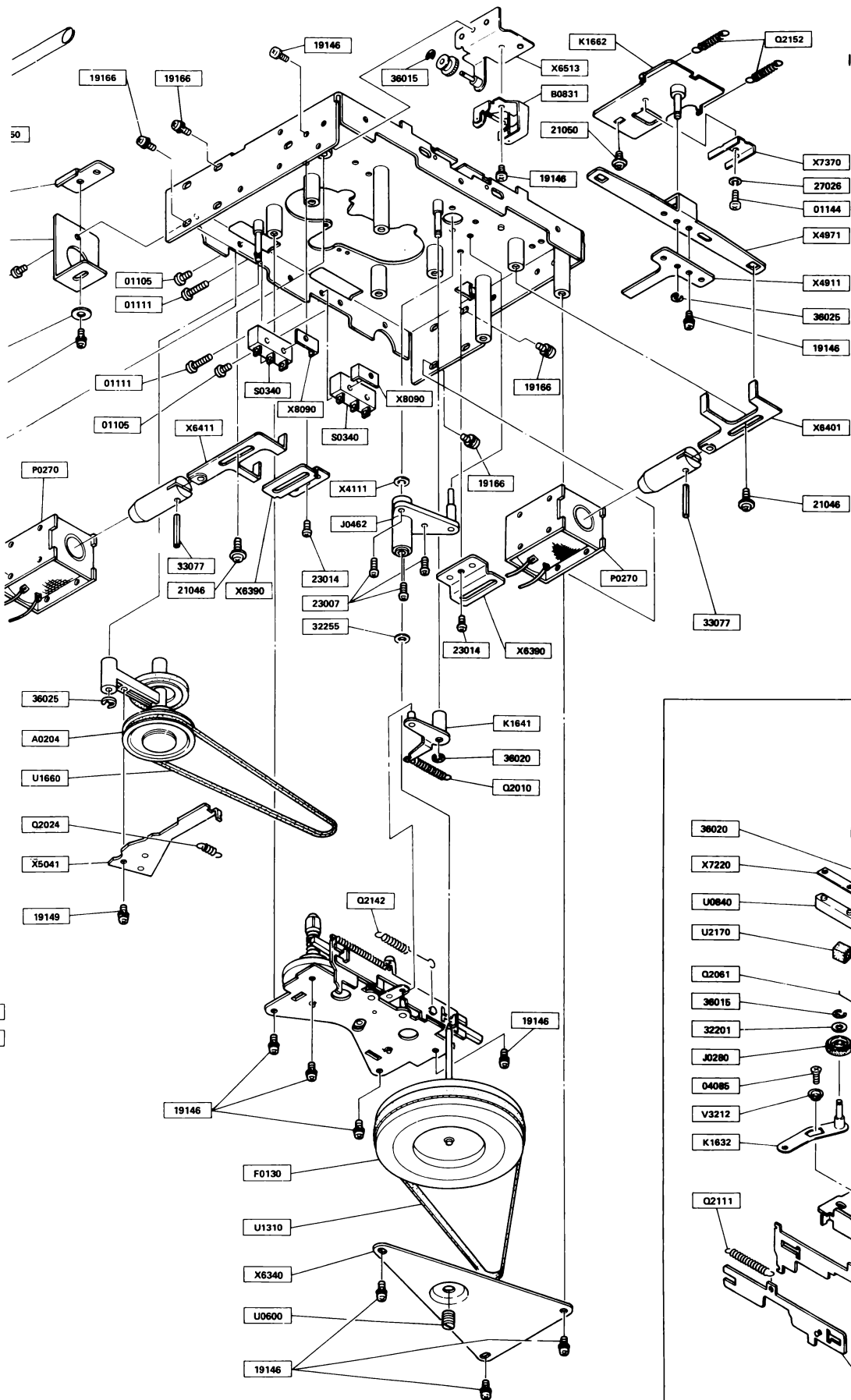

FD-710 MK 2

POWER SUPPLY BOARD (DPS-183-1)

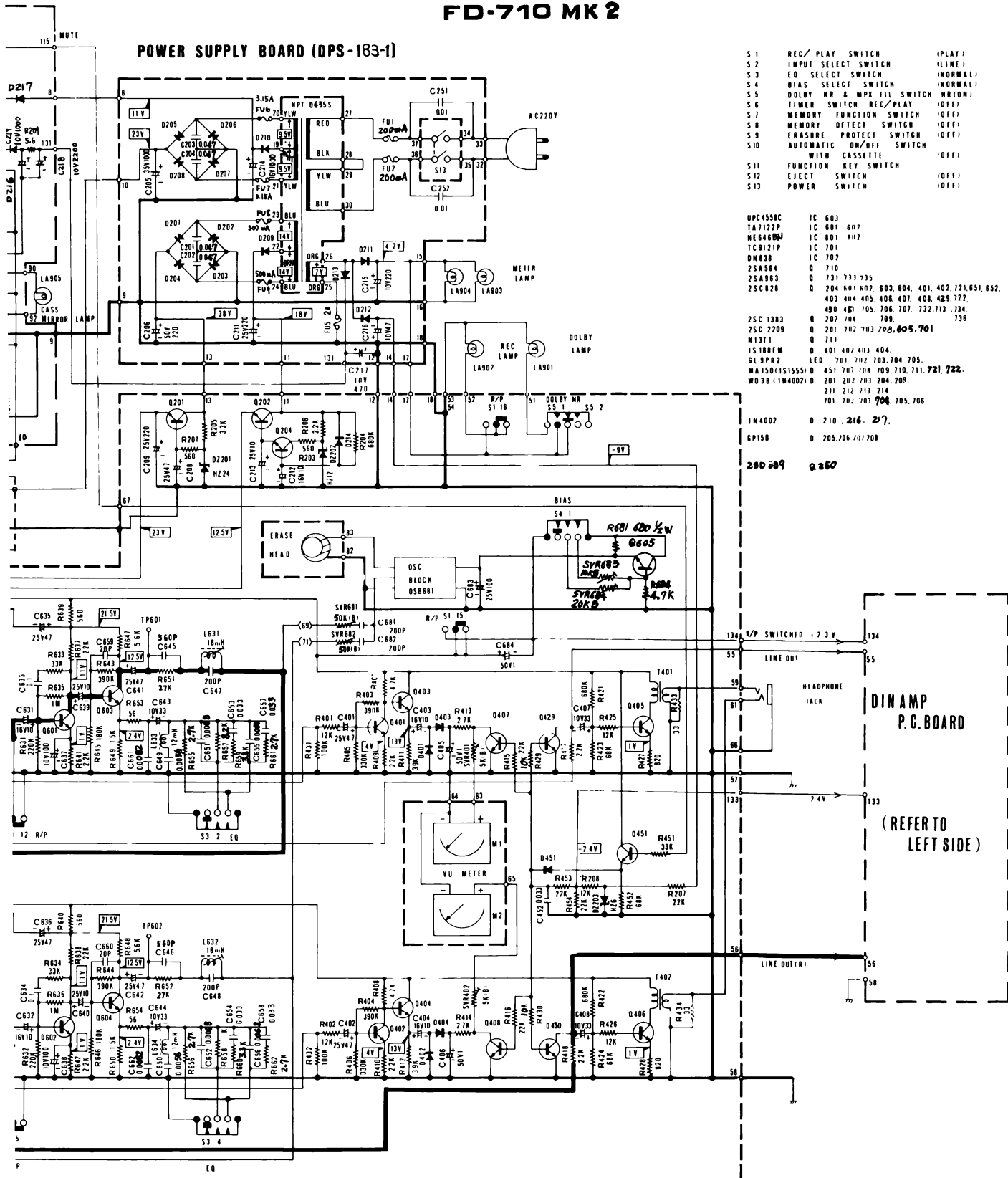

- S 1 REC/ PLAY SWITCH (PLAT)
- S 2 INPUT SELECT SWITCH (LINE)
- S 3 EQ SELECT SWITCH (NORMAL)
- S 4 BIAS SELECT SWITCH (NORMAL)
- S 5 DOLBY NR & MPX FIL SWITCH (NR ON)
- S 6 TIMER SWITCH REC/PLAY (OFF)
- S 7 MEMORY FUNCTION SWITCH (OFF)
- S 8 MEMORY EFFECT SWITCH (OFF)
- S 9 ERASURE PROTECT SWITCH (OFF)
- S 10 AUTOMATIC ON/OFF SWITCH (OFF)
- S 11 WITH CASSETTE (OFF)
- S 12 FUNCTION KEY SWITCH (OFF)
- S 13 EJECT SWITCH (OFF)
- S 13 POWER SWITCH (OFF)

- UPC458C IC 603
- TA7122P IC 601, 602
- WE6480M IC 801, 802
- IC9121P IC 701
- DM83 IC 702
- 2SA564 Q 710
- 2SA963 Q 731, 733, 735
- 2SC828 Q 204, 401, 402, 603, 604, 401, 402, 721, 651, 652, 403, 404, 405, 406, 407, 408, 429, 722, 430, 431, 705, 706, 707, 732, 713, 734
- 2SC1383 Q 202, 704, 708, 736
- 2SC2209 Q 201, 702, 703, 708, 605, 701
- W4371 Q 711
- 15188FM Q 401, 402, 403, 404
- ELSPR2 LED 701, 702, 703, 704, 705
- WA150X1S15551 Q 451, 707, 708, 709, 710, 711, 721, 722
- WD3B (1N4002) D 201, 202, 203, 204, 209, 211, 212, 213, 214, 701, 702, 703, 704, 705, 706
- 1N4002 D 210, 216, 217
- 6P15B D 205, 706, 707, 708

250 289 Q 260

DIN AMP P.C. BOARD
 (REFER TO LEFT SIDE)

ZER, DOLBY, REC AMP BOARD (DAM-301)

CIRCUIT DIAGRAM

LOGIC CONTROL BOARD (DLC-1381B)

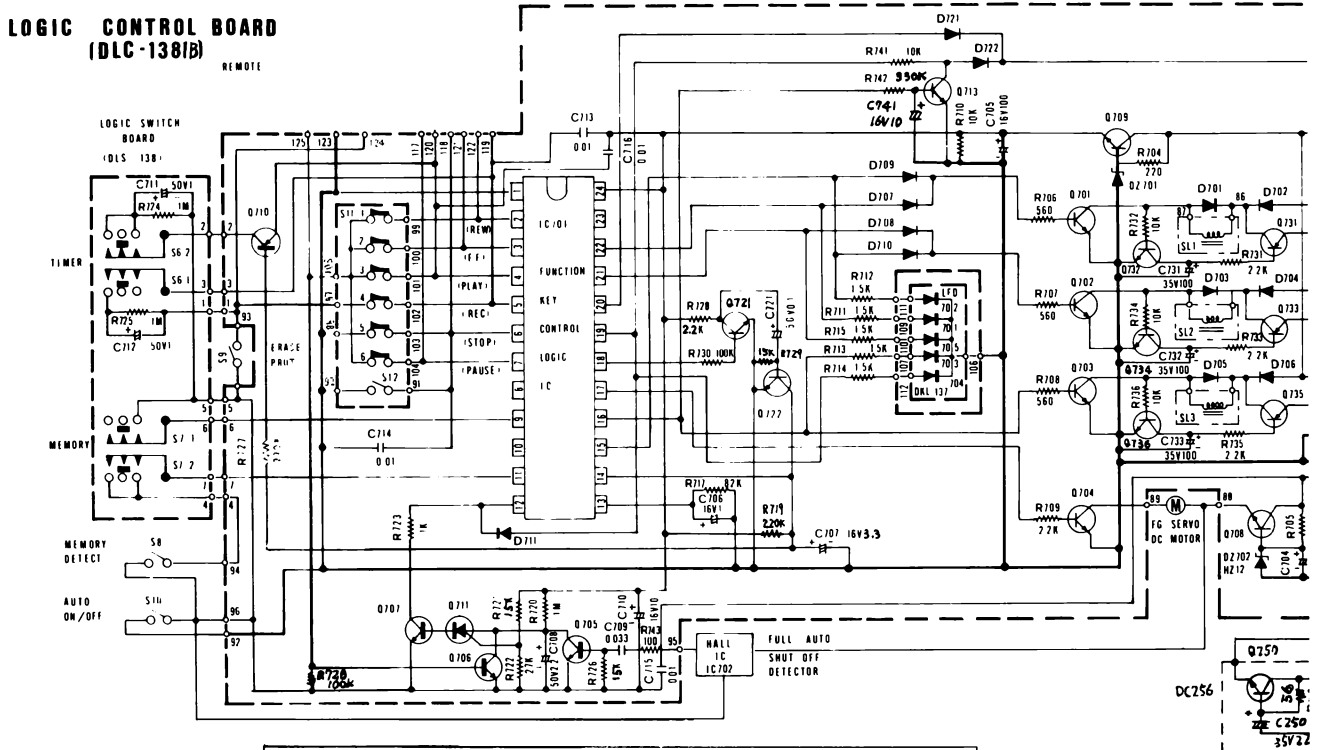

DIN AMP P.C. BOARD DDA-167A

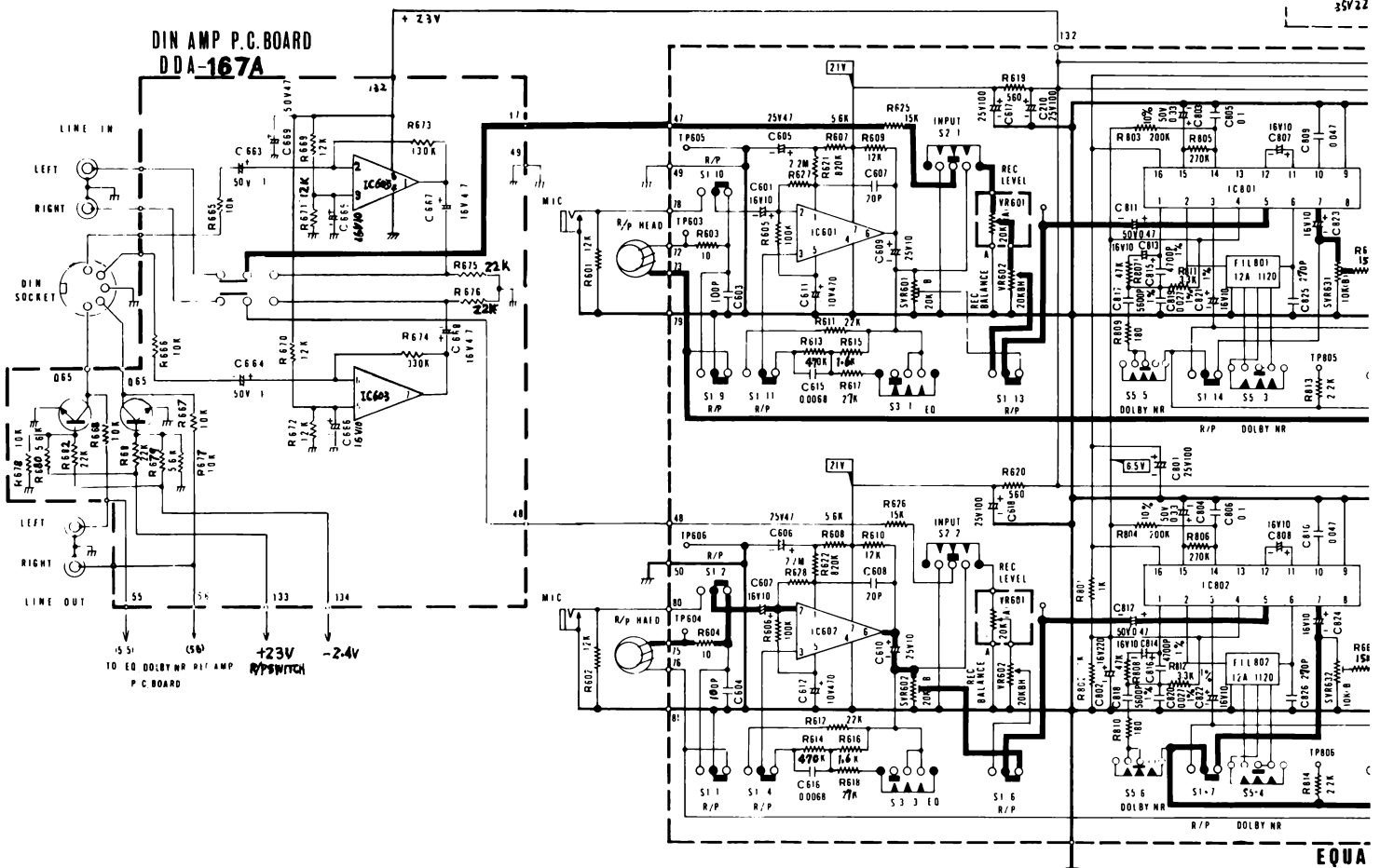

FRONT VIEW

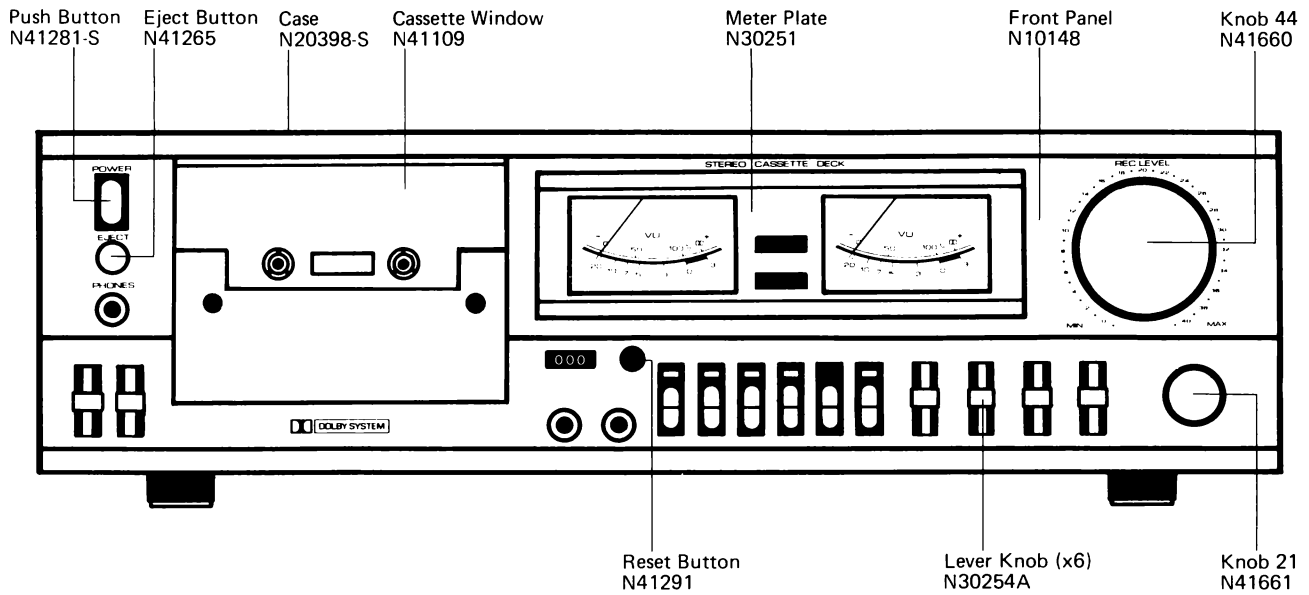

BLOCK DIAGRAM

